

MADE IN THE USA

# DRILLING TOOLS CATALOG

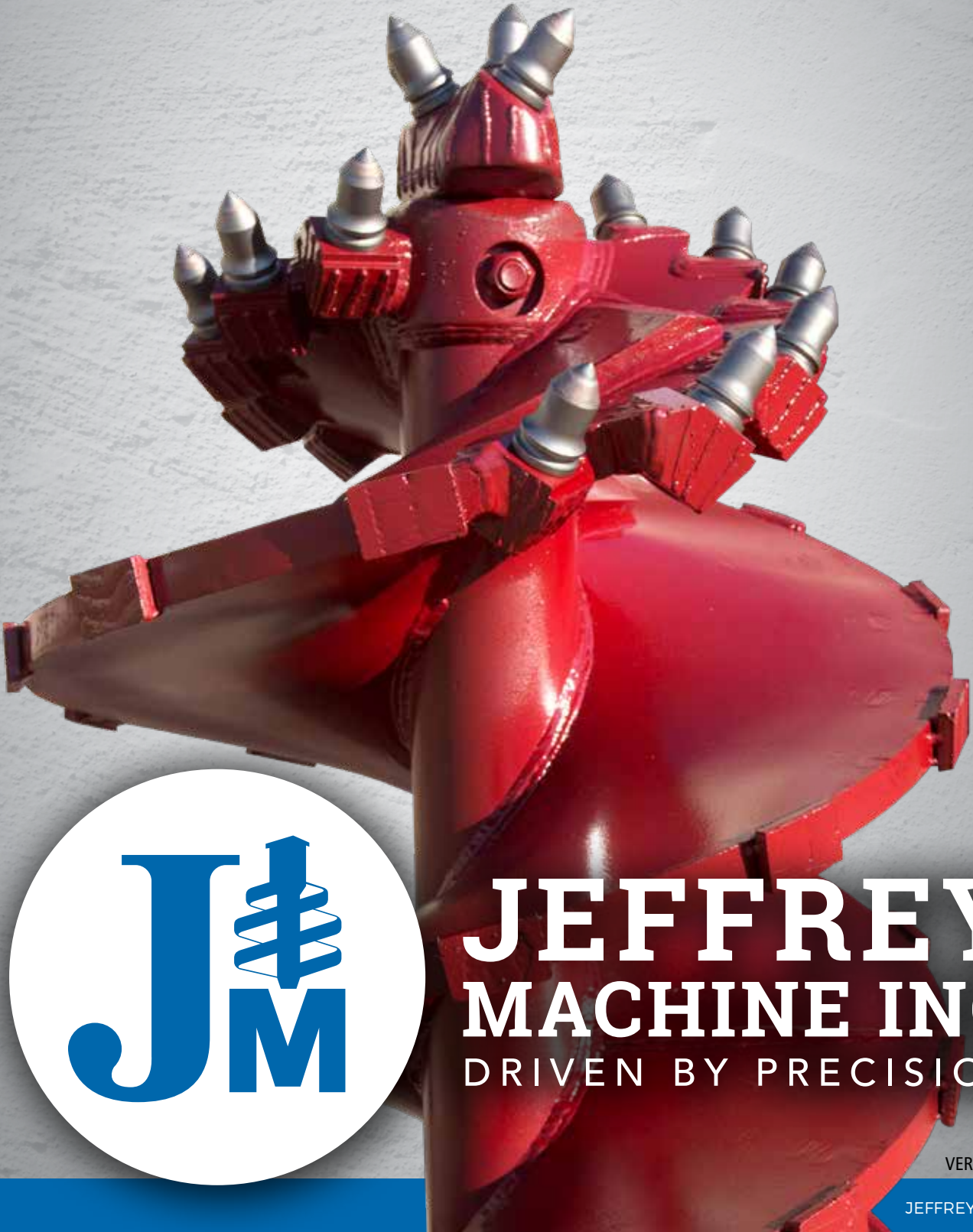

**JEFFREY  
MACHINE INC**  
DRIVEN BY PRECISION

VER. 5

[JEFFREYMACHINE.COM](http://JEFFREYMACHINE.COM)

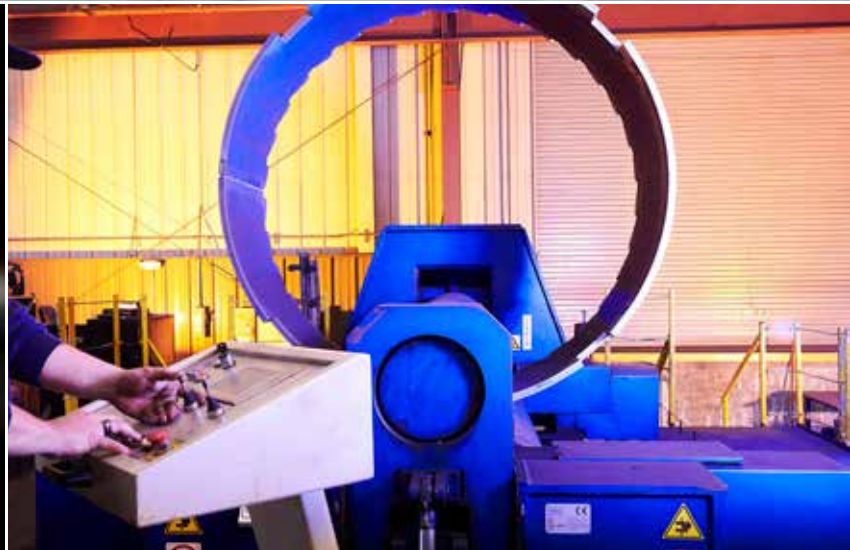
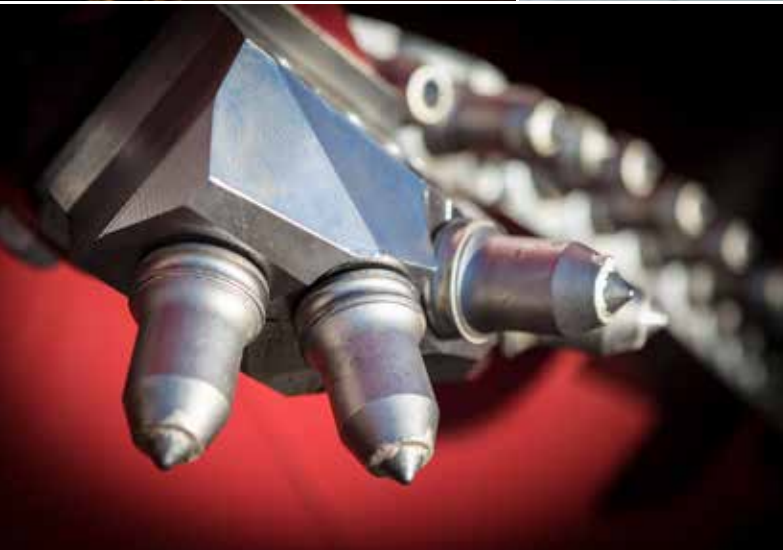

# TABLE OF CONTENTS

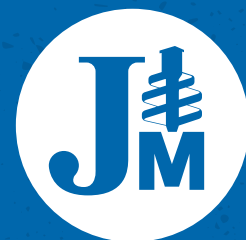

## HOW TO ORDER ..... 6

Tungstuds.....9  
Wear Protection & Laminates .....12

## FOUNDATION TOOLS & ACCESSORIES

Rock Augers .....14  
Pilotless Augers.....16  
Multi-Purpose Augers.....17  
Crimson Crusher®.....18  
Christmas Tree™ Auger .....19  
Pressure Auger .....20  
Econo Auger® .....21  
Spoon™ Auger .....22  
Dirt Augers .....23  
Slurry Auger .....24  
Casing.....25  
Casing Twister .....26  
Continuous Flight Augers (CFA's) .....28  
Soil Mixing Tool.....30  
Spline Couplers .....31  
CFA Hex Couplers.....32  
CFA Threaded Couplers .....33  
Boulder Extractors.....34  
Auger Reaming Arms .....35  
Core Barrels .....40  
Roller Cone Barrel .....42  
Core Rings & Custom Plate Rolling .....44  
Belling Tool .....45  
Cross-Cut Core Barrels .....46  
Rock Mills .....47  
Drilling Buckets .....48  
Clean Out Buckets .....54  
Drilling Bucket Parts .....56  
Open Spin Top Bottom Clean Out Buckets.....60  
Retrieval Buckets.....61

## ACCESSORIES & WEAR ITEMS

Drive Boxes .....63  
Shim Boxes .....69  
Teeth .....71  
Holders.....74  
Teeth & Holders.....76  
Pilot Bits.....78  
Miscellaneous Parts .....80

## DERRICK AUGERS & ACCESSORIES

Derrick Auger Features & Benefits.....83

## HOW TO ORDER ..... 84

Medium Duty Auger 4 Basic Set-Ups.....85  
Utility Dirt Tooth Auger.....86  
Medium Duty Bolt-On Carbide Auger.....87  
Medium Duty Bullet Tooth Auger .....88  
Medium Duty Dragon's Tooth® Auger .....89  
Medium Duty Bolt-On Bullet Tooth Auger .....90  
Medium Duty Bolt-On Dragon's Tooth® Auger .....91  
Spiral Dragon's Tooth® Rock Auger .....92  
Hex Couplers, Hubs & Adapters.....94  
Medium Duty Center Heads .....95  
Shank Plates .....96  
Shank Kits .....97  
Twin Helix Auger .....98  
Teeth & Holders.....99  
Pilot Bits & Adapters .....104  
Kelly Bars .....106  
Derrick Core Barrel.....107

## LIGHT DUTY AUGERS & ACCESSORIES

Light Duty Rock & Dirt Augers.....108  
Light Duty Teeth & Accessories.....109  
Light Duty Auger Rack.....110

## ANCHOR PLACEMENT TOOLS

6 Bolt Kelly Bar Adapters & Locking Dog .....112  
SS Helical Pier Anchor Drive Tools .....112  
12 Bolt Kelly Bar Adapters & Locking Dog .....113  
Drive End Wrenches & Extensions.....114

## PERFORMANCE TEAM SET-UP ..... 116

## TRUCK ACCESSORIES..... 118

## FLIGHTING..... 121





# TOOLS AVAILABLE TO RENT

Jeffrey Machine is now offering tools for rental including augers and core barrels; from 24" to 120" in diameter. A wide range of utility tools from 9" to 32" in diameter are also available through our rental program. Call a Jeffrey Machine representative today at 205.841.8600.

Rock & Dirt Augers  
Clean Out Buckets  
Casing Twisters  
Drilling Buckets

Belling Tools  
Core Barrels  
Derrick Augers & Parts  
Continuous Flight Augers

[jeffreymachine.com/tool-rental/](http://jeffreymachine.com/tool-rental/)

Contact a Jeffrey Machine representative today!

# HOW TO ORDER

## CHOOSE AN AUGER

Available in sizes up to 12' in diameter. All of our augers are manufactured in house.

**ROCK**      **DIRT**      **MULTIPURPOSE**      **CRIMSON CRUSHER**

Modification options available on page 7.

## SELECT AUGER TYPE

Jeffrey Machine is proud to be the "go-to" manufacturer for high quality custom-built augers. There are six basic types of spiral augers.



**TYPE 1**

**Double Cut,  
Double Flight**

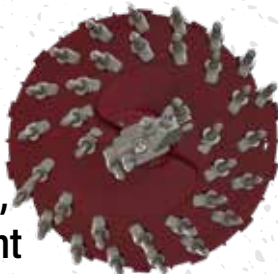

**TYPE 2**

**Double Cut,  
Double Flight**

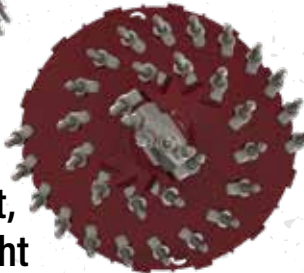

**TYPE 3**

**Double Cut,  
Double Flight**



**TYPE 4**

**Double Cut,  
Double Flight**



**TYPE 5**

**Double Cut,  
Double Flight**



**TYPE 6**

**Double Cut,  
Double Flight**

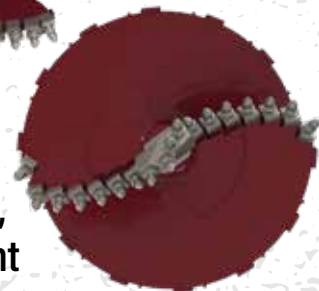

# HOW TO ORDER

## SELECT YOUR MODIFICATIONS

There are hundreds of modifications that can be made to specifically fit your application.

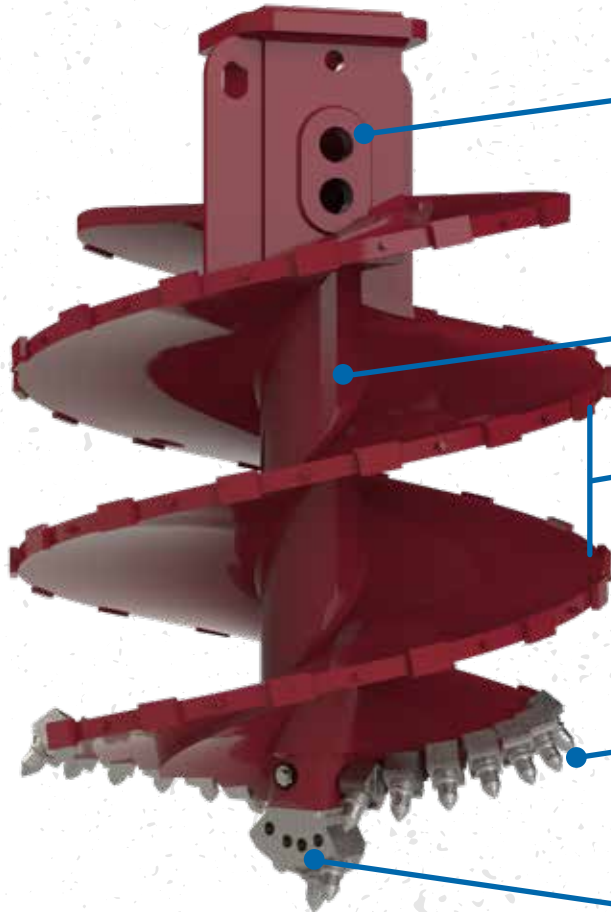

### DRIVE BOXES

Fabricated steel boxes are available in a variety of sizes. Manufactured in-house, drive boxes are rated for maximum rotational torque & pull-out force. **SEE PAGE 63.**

### CENTER SHAFT

Available from 4" OD to 13" OD.

### FLIGHTING

There are multiple variants to choose from including

- Outside Diameter
- Pitch
- Inside Diameter
- Thickness
- Right or Left Handed

**FOR MORE INFO, SEE PAGE 121.**

### TEETH & HOLDERS

For a list of all teeth and holders available, **SEE PAGE 71.**

### PILOTS, ADAPTERS, AND HUBS

For a list of all available, **SEE PAGE 78.**

## ADD-ON FEATURES

Additional features to add-on for even more customization.

### WEAR PROTECTION



Wear Pads  
& Carbide Studs

Fully Hard  
Surface



Full Hard Surface  
Outer Edge

**LEARN MORE ON PAGE 12.**

### LAMINATES



**LEARN MORE ON PAGE 13.**

### REAMING ARMS



**LEARN MORE ON PAGE 35.**

Custom orders cannot be refunded, canceled, or returned for any reason.



Tungstuds by **Betek** reduce wear over time due to the carbide core. Tungstuds are easy to install & quick to replace.

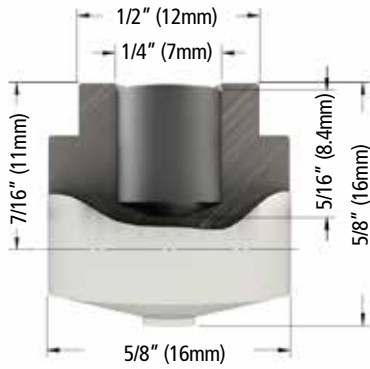

**BTS01**

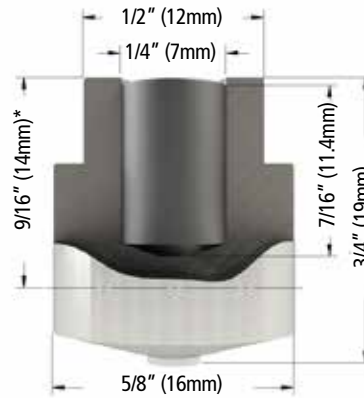

**BTS02**

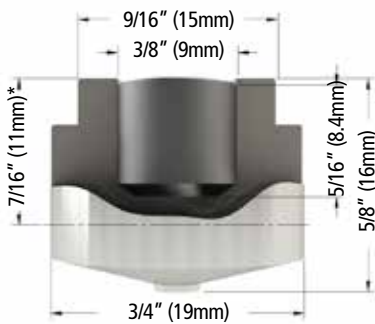

**BTS03**

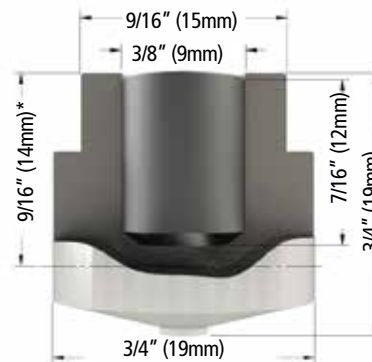

**BTS04**

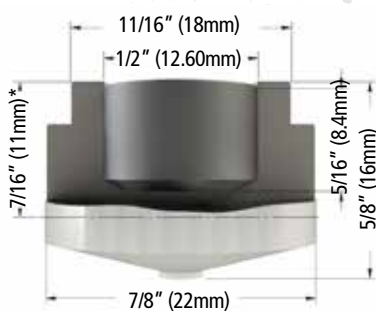

**BTS05**

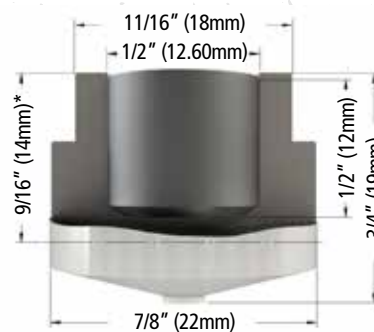

**BTS06**

\*Height after welding.

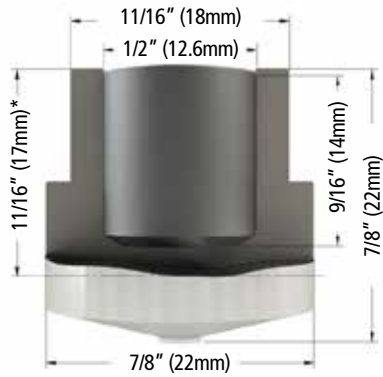

**BTS07**



**BTS08**

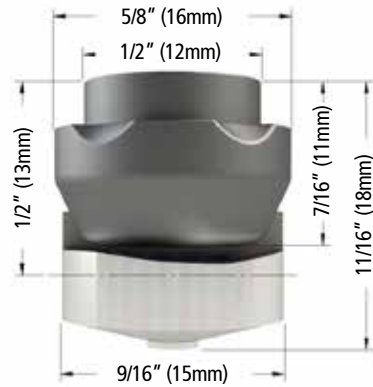

**BTS10B**



**BTS20**

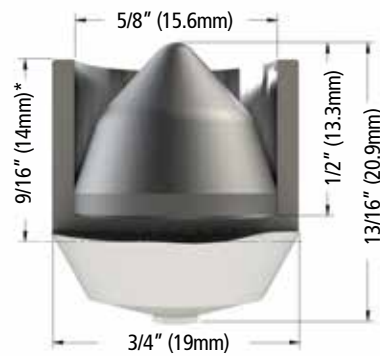

**BTS100**

\*Height after welding.



ORIGINAL PARTS

 **BETEK**

**BETEK**

ORIGINAL PARTS



# WEAR PROTECTION

Wear Protection can greatly increase the life of your drilling tools. Whether adding any of these options to a new auger or having Jeffrey Machine refurbish your used tool, it's a great way to protect your investment.



## WEAR PADS

These have become extremely popular as they offer extra wear protection. When they do start to wear down, it's a simple task to weld a new pad in the available space beside it.



## CARBIDE STUDS

Also known as tungstuds can be applied to any surface to add wear protection. Fast and easy to install carbide studs will add an adequate amount of wear protection extending the life of your tooling.

Reference pg. 9-10.



## FULL HARD SURFACE OUTER EDGE

Adding hard surface welding wire to the outside edge of your tooling will extend the life of your auger, *(Most popular on dirt augers.)*

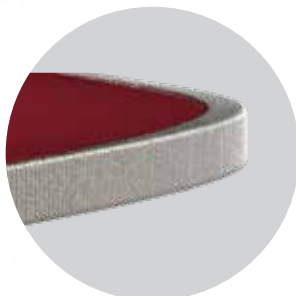

## FULLY HARD SURFACE

Our Fully Hard Surface option increases your protection even further by adding an extra 1" of wire to the top and bottom side of the auger flighting.



# LAMINATES

Laminates have been added to all of our 30" and larger heavy duty rock augers. (Optional for dirt augers)

Laminates greatly increase the strength of flighting for crowd (pushing down), torque (twisting) and load (pulling heavy spoil up out of the ground). Jeffrey Machine has developed a reputation for building the highest quality augers in the industry. Laminates are just one more enhancement to insure our augers hold up to the ever increasing power of modern drilling rigs.

# ROCK AUGER

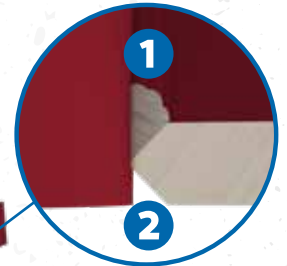

All flights are double beveled for better weld penetration.

- 1 Bevel with weld
- 2 Bevel pre-weld

## COMPATIBLE PILOTS



RP-4 Machined Pilot  
P/N 40285



.990 Dragon's Tooth® Pilot Cast  
P/N 40205

## COMPATIBLE PILOT ADAPTERS



2-1/2" SQ Pilot Adapter  
P/N 42040



177mm x 100mm FM Adapter  
P/N 42080

## COMPATIBLE DRIVE BOXES

P/N 43525	3" Kelly Drive Box	P/N 43695	150mm Kelly Drive Box
P/N 43535	3-1/2" Kelly Drive Box	P/N 43615	7" Kelly Drive Box
P/N 43545	4" Kelly Drive Box	P/N 43670	200mm Standard Tall 18"
P/N 43555	4-1/4" Kelly Drive Box	P/N 43671	200mm Standard Short 18"
P/N 43680	4-1/2" Kelly Drive Box	P/N 43676	200mm HD Tall 18"
P/N 43560	5" Kelly Drive Box	P/N 43677	200mm HD Short 18"
P/N 43575	5-1/4" Kelly Drive Box	P/N 43679	200mm HD Tall Deep 21.5"
P/N 43595	130mm Kelly Drive Box	P/N 43678	200mm Standard Tall Deep 21.5"
P/N 43600	6" Kelly Drive Box		

## 38MM TEETH & HOLDERS

### 38mm TEETH (Only compatible with 38mm Holders)



**38mm Dragon's Tooth®**  
P/N 30188



**BKH113**  
P/N 30225



**B47K22-H**  
P/N 30212



**BFZ 100X70/2**  
P/N 34172



**B47K19H**  
P/N 30162



**B47K19L**  
P/N 30182



**55-1S/C4-1**  
P/N 30242

### 38mm HOLDERS (Only compatible with 38mm Teeth)



**38mm Dragon's Tooth® Holder**  
P/N 32058



**38mm Tri-Holder**  
P/N 32064



**JM-48 Holder**  
P/N 32061



**JM-43 Holder**  
P/N 32050



**38mm Jeff444 Tri-Holder**  
P/N 32102

## .990 TEETH & HOLDERS

### .990 TEETH (Compatible with .990 Holders)



**.990 Dirt Tooth**  
P/N 34380



**.990HB**  
P/N 30122



**.990 Dragon's Tooth®**  
P/N 30145



**B40 HDS**  
P/N 30155

### .990 HOLDERS (Compatible with .990 Teeth)



**.990 Dragon's Tooth® Holder**  
P/N 32049



**.990 Tri-Holder**  
P/N 32042



**JM C-30 Holder**  
P/N 32040



**.990 Jeff444 Tri-Holder**  
P/N 32104

# PILOTLESS AUGER

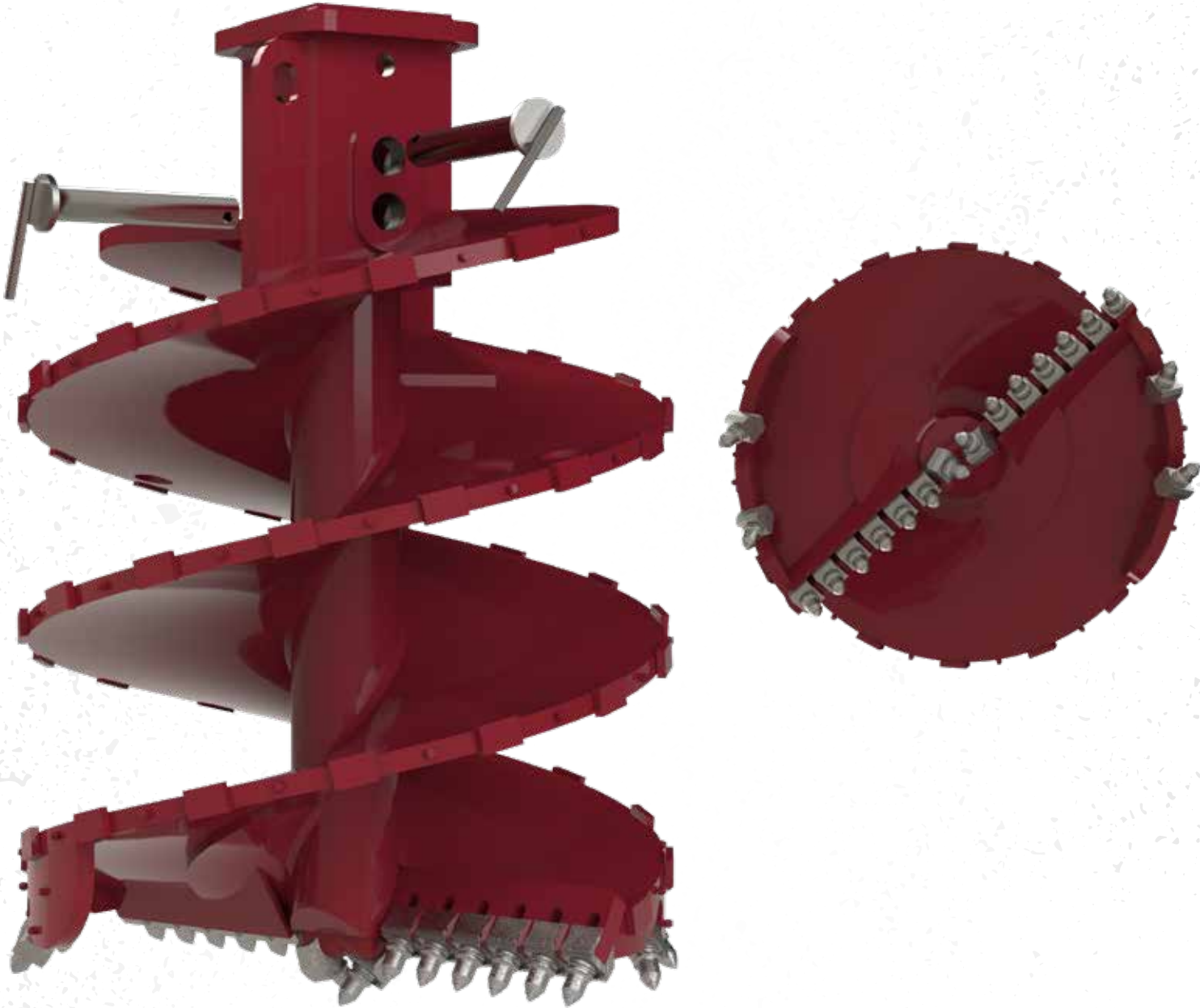

## PILOTLESS AUGER SPECIFICATIONS

**Commonly Requested Diameters:** 14" – 144" \*

**Type:** Type 6

**Cut:** DC/DF

**Kelly boxes:** All kelly boxes made to customer specifications

**Center Shaft:** 6" OD – 8" OD

**Flight:** 1" – 2" thickness available

All flight ID is beveled for better weld penetration  
Laminate flight on all augers 30" or larger

**Wear Protection:** Wear Pads 2" x 3" x 1/2" (39302)

\* Smaller diameters available based on Kelly box size / custom sizes greater than 144"



**.990HB**  
P/N 30122



**B47K19L**  
P/N 30182



**.990 Dragon's Tooth®**  
P/N 30145



**38mm Dragon's Tooth®**  
P/N 30188



**.990 Tri-Holder**  
P/N 32042



**38mm Tri-Holder**  
P/N 32064

All .990 and 38mm rock augers are manufactured with Tri Holders.  
Smaller conical teeth available upon request.

# MULTI-PURPOSE AUGER

Optimize your drilling tool fleet with the multi-purpose auger. This auger can be utilized as a dirt or rock auger simply by switching out the tooth & pilot combinations.

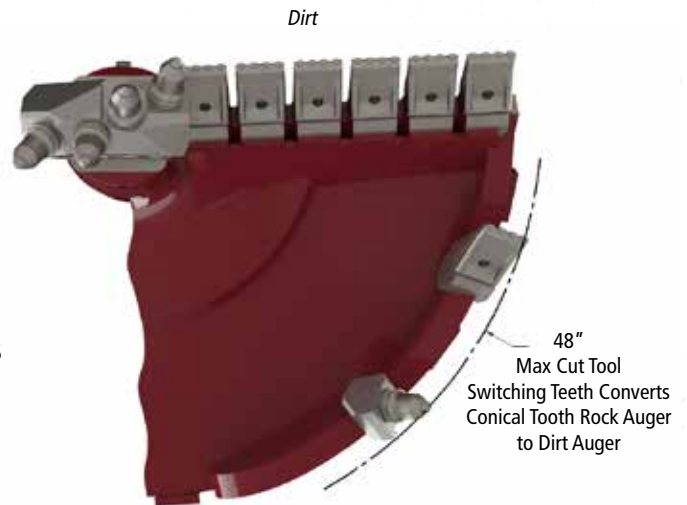
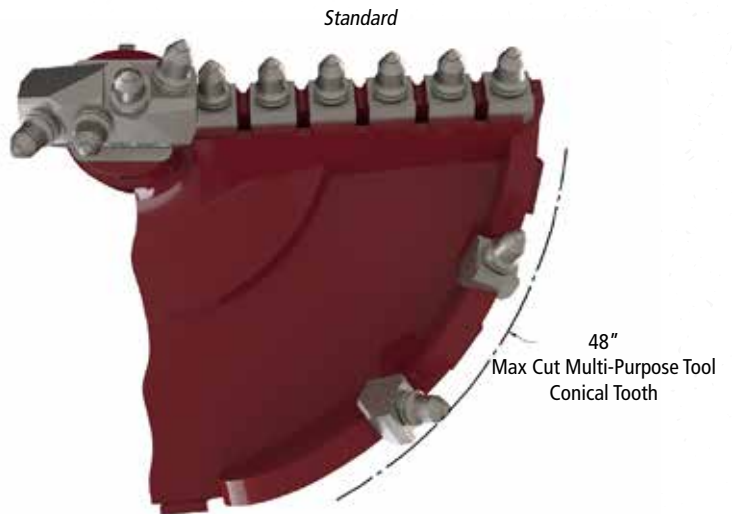

## MULTI-PURPOSE AUGER SPECIFICATIONS

Commonly Requested Diameters: 16" – 144"\*

Type: Type 3 - 6

Cut: DC/DF

Kelly boxes: All kelly boxes made to customer specifications

Center Shaft: 4" OD – 12" OD (Solid shaft available in some sizes)

Flight: 1" – 2" thickness available

All flight ID is beveled for better weld penetration

Laminate flight on all augers 30" or larger

Wear Protection: Wear Pads 2" x 3" x 1/2" (39302)

\* Smaller diameters available based on Kelly box size / custom sizes greater than 144"

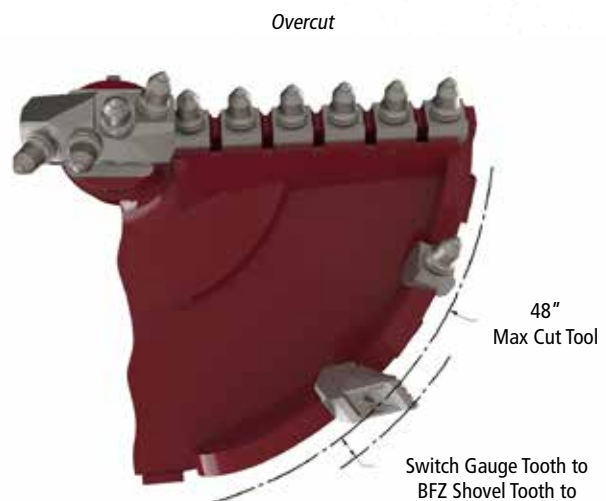

ROCK



**B47K19L**  
P/N 30182



**38mm Tri-Holder**  
P/N 32064



**RP-4 Machined Pilot**  
P/N 40285

DIRT



**JMI 113x70/D**  
P/N 34241



**BFZ 100x70/2**  
P/N 34172



**38mm Tri-Holder**  
P/N 32064



**4" SQ. JM 8" Dirt Pilot**  
P/N 40260

# CRIMSON CRUSHER® AUGER

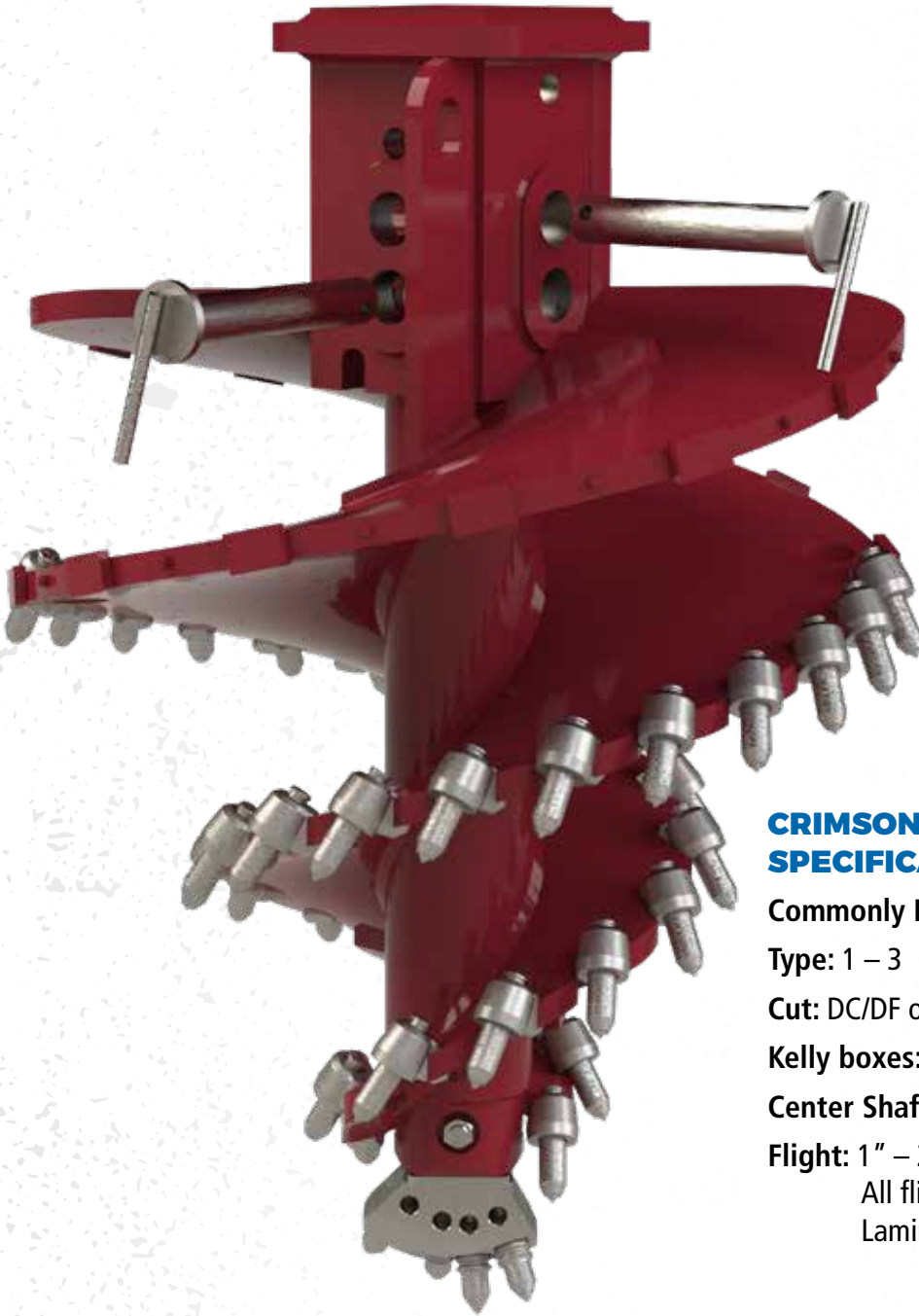

## CRIMSON CRUSHER® SPECIFICATIONS

**Commonly Requested Diameters:** 18" – 144"

**Type:** 1 – 3

**Cut:** DC/DF or SC/SF

**Kelly boxes:** All kelly boxes made to customer specifications

**Center Shaft:** 4" OD – 12" OD (Solid shaft available in some sizes)

**Flight:** 1" – 2" thickness available

All flight ID is beveled for better weld penetration

Laminate flight on all augers 30" or larger



**.990HB**  
P/N 30122



**55-1S / C4-1**  
P/N 30242



**JM C-30 Holder**  
P/N 32040



**JM-43 Holder**  
P/N 32050

# CHRISTMAS TREE™ AUGER

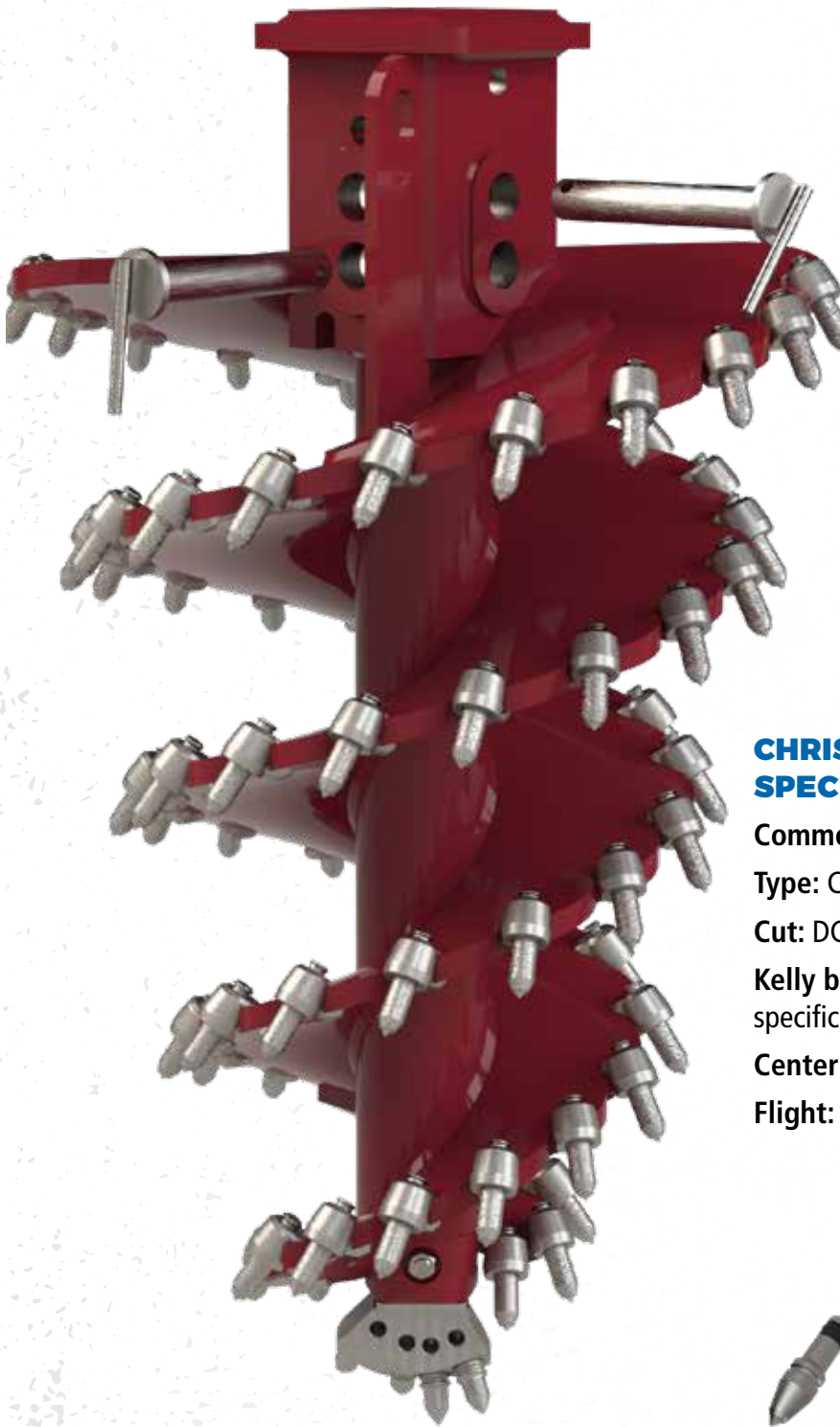

## CHRISTMAS TREE™ AUGER SPECIFICATIONS

**Commonly Requested Diameters:** 24" – 60"

**Type:** Christmas Tree

**Cut:** DC/DF or SC/SF

**Kelly boxes:** All kelly boxes made to customer specifications

**Center Shaft:** 4" OD – 12" OD (Solid shaft available in some sizes)

**Flight:** 1" – 2" thickness available

All flight ID is beveled for better weld penetration  
Laminate flight on all augers 30" or larger



**.990HB**  
P/N 30122



**55-1S / C4-1**  
P/N 30242



**JM C-30 Holder**  
P/N 32040



**JM-43 Holder**  
P/N 32050

# PRESSURE AUGER

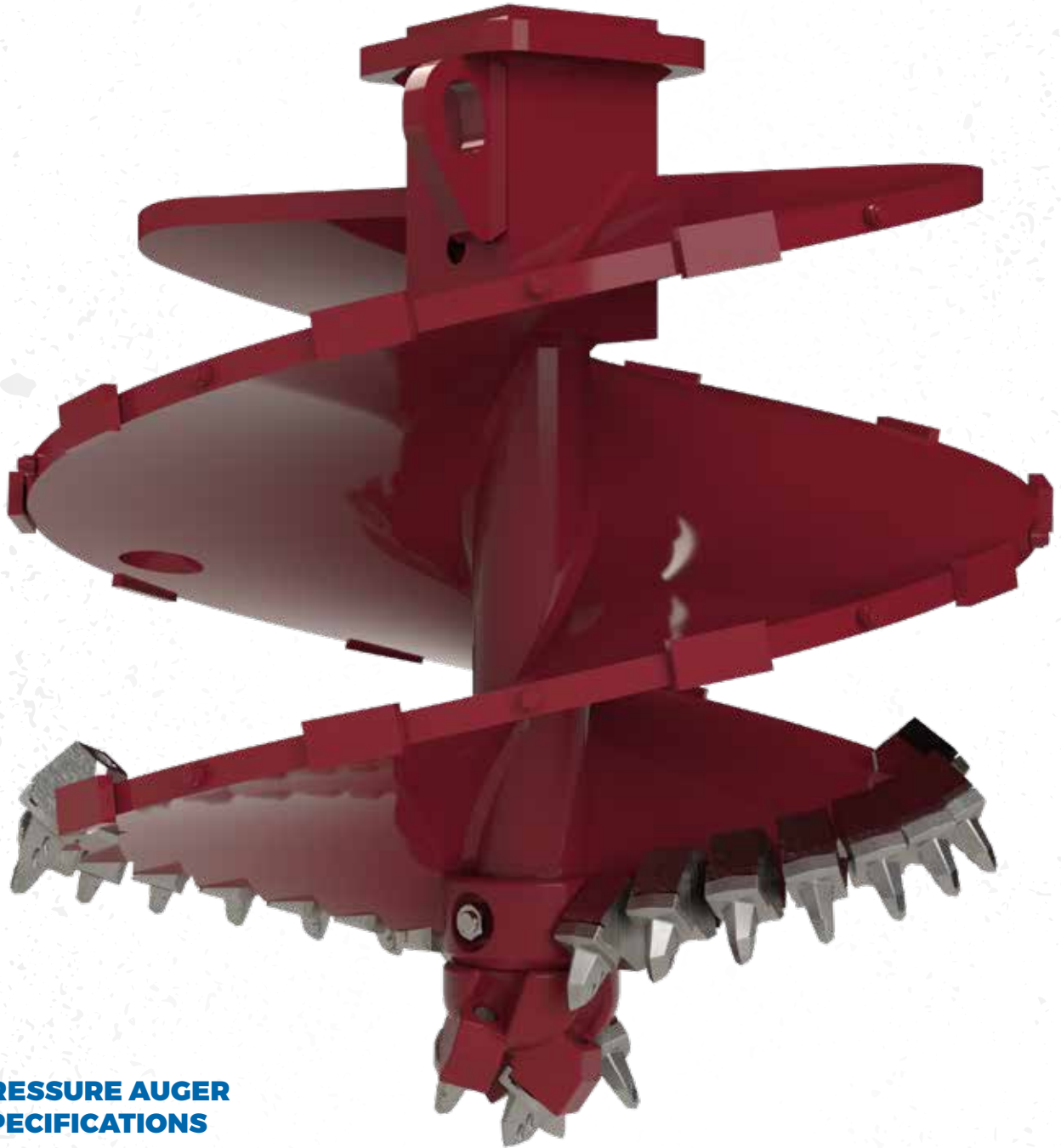

## PRESSURE AUGER SPECIFICATIONS

**Standard Height:** 36" – 42"

**Commonly Requested Diameters:** 24" – 60"

**Type:** Types 4 – 6

**Cut:** DC/DF or SC/SF

**Kelly boxes:** 3" - 4" box

**Center Shaft:** 4" OD – 8" OD (Solid shaft available in some sizes)

**Flight:** 1" thickness available

All flight ID is beveled for better weld penetration

Laminate flight on all augers 30" or larger



**.990HB**  
P/N 30122



**.990 Dirt Tooth**  
P/N 34380



**.990 Dragon's Tooth®**  
P/N 30145



**.990 Tri-Holder**  
P/N 32042



**JM C-30 Holder**  
P/N 32040

# ECONO AUGER®



## ECONO AUGER® SPECIFICATIONS

**Commonly Requested Diameters:** 18" – 60"

**Type:** 4 & 5

**Cut:** DC/DF

**Kelly boxes:** All kelly boxes made to customer specifications

**Center Shaft:** 4" OD – 6" OD (Solid shaft available in some sizes)

**Flight:** 1" thick flights only

All flight ID is beveled for better weld penetration



**.990HB**  
P/N 30122



**55-1S / C4-1**  
P/N 30242



**JM C-30 Holder**  
P/N 32040



**JM-43 Holder**  
P/N 32050

# SPOON™ AUGER



Spoon™ Augers are best used in applications when overhead space is restricted. Flaps increase the ability to hold loose spoil on the auger flights preventing material from falling back into the shaft. If you have questions regarding the spoon or bow tie augers, please contact a Jeffrey Machine Inc. representative.

# DIRT AUGERS



DC/SF

Side skirt options available



SC/SF

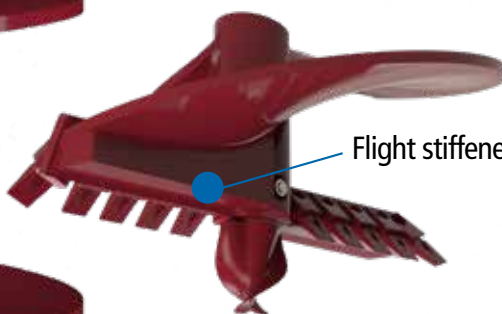

Flight stiffener options available

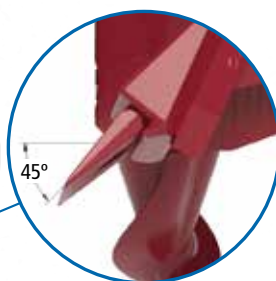

45°



SC/SF

## DIRT AUGER SPECIFICATIONS

**Commonly Requested Diameters:** 14" – 144" \*

**Type:** Type 6

**Cut:** DC/DF, DC/SF, SC/SF

**Kelly boxes:** All kelly boxes made to customer specifications

**Center Shaft:** 4" OD – 12" OD (Solid shaft available in some sizes)

**Flight:** 1" – 2" thickness available

All flight ID is beveled for better weld penetration

**Wear Protection:** Hard Surface Outer Edge

\* Smaller diameters available based on Kelly box size / custom sizes greater than 144"



101 Dirt Tooth  
P/N 34070



WO1 Holder  
P/N 36000



201 Dirt Tooth  
P/N 34100



WO-5 Holder  
P/N 36010



211 Dirt Tooth  
P/N 34110



2.5" SQ. JM-08  
Dirt Pilot  
P/N 40470



4" SQ. JM 8"  
Dirt Pilot  
P/N 40260



4" SQ. JM 12"  
Dirt Pilot  
P/N 40264

# SLURRY AUGER



## SLURRY AUGER SPECIFICATIONS

**Standard Height:** 24" - 96"

**Commonly Requested Diameters:** 24" – 60"

**Type:** Types 5 – 6

**Cut:** DC/DF or SC/SF

**Kelly boxes:** All Kelly boxes made to customer specifications

**Center Shaft:** 14" – 24"

**Flight:** 1" to 1-1/2" thick available

**Wear Protection:** Hard Surface outside edge or fully hard surface



**201 Dirt Tooth**  
P/N 34100



**WO-5 Holder**  
P/N 36010



◀ 4 gallon square buckets weighing 22 pounds per bucket

## POLY-BORE

POLY-BORE polymer is a free flowing, water-soluble, easy mixing, 100% dry granular polymer. When mixed with fresh water, a small quantity of POLY-BORE polymer provides a clear, solid-free, viscous borehole stabilizing fluid for use in drilled shaft, auger drilling, horizontal directional boring, trenching excavation and reverse circulation (RC) rotary drilling. POLY-BORE polymer is not designed to be used in conjunction with bentonite-based fluids.

P/N 799-7004

## EZ-MUD

EZ-Mud is a clay and shale stabilizer provides inhibition of clay and shale formations in water-based drilling fluids without substantially increasing viscosity. EZ-MUD GOLD stabilizer, when added to a QUIK-GEL® or BORE-GEL® slurry, yields an inhibitive drilling fluid system while maintaining manageable and effective fluid properties. EZ-MUD GOLD stabilizer can be mixed easily at minimal shear thereby eliminating the need for liquid emulsions.

P/N T799-2000

## QUIK-GEL

Quik-Gel is a viscosifier is an easy-to-mix, finely ground (200-mesh), premium-grade, high-yielding Wyoming sodium bentonite. QUIK-GEL viscosifier imparts viscosity, fluid loss control and gelling characteristics to freshwater-based drilling fluids.

P/N T799-1000

# CASING



Casing



Casing Driver

## CASING CAPABILITIES

Inner Diameters: 22" - 144"

Wall: 3/8" - 1" thick available



CJ2 Holder  
P/N 36070



CJ2 Tooth  
P/N 34220



3/4" Hex Weld Bars  
P/N 34350



1 1/8" Hex Weld Bars  
P/N 34340



1 3/8" Hex Weld Bars  
P/N 34330

Custom sizes available.

# CASING TWISTERS

## 2 Way Adjustable Casing Twister with 5" OD Solid Arms\*

- 2 Way 30" - 42"
- 2 Way 48" - 72"
- 2 Way 78" - 122"

\*Other sizes and 4 way are available.



*Exploded View*



**4 Way Adjustable Casing Twister with 5" OD Solid Arms\*\***

- 4 Way 30" - 42"
- 4 Way 48" - 72"
- 4 Way 78" - 122"

\*\*Other sizes and 2 way are available.

**4-Way Adjustable Casing Twister Ratings**

30" - 42"		48" - 72"		78" - 122"	
Maximum Torque		Maximum Torque		Maximum Torque	
Extended	Retracted	Extended	Retracted	Extended	Retracted
200,000ft-lbs.	425,000ft-lbs.	485,714ft-lbs.	485,714ft-lbs.	485,714ft-lbs.	680,000ft-lbs.
Maximum Lift		Maximum Lift		Maximum Lift	
Extended	Retracted	Extended	Retracted	Extended	Retracted
308,108lbs.	737,864lbs.	182,138lbs.	760,000lbs.	126,666lbs.	950,000lbs.

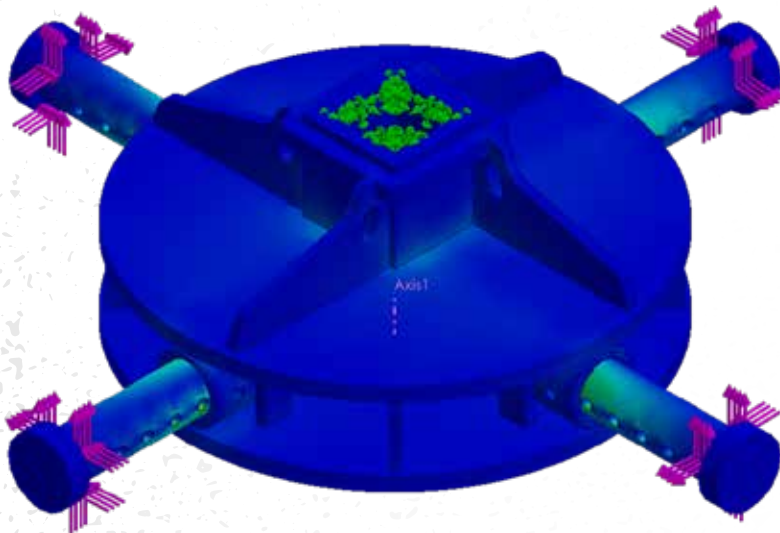

von Mises (psi)

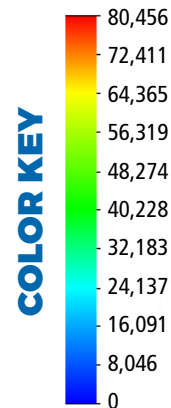

→ Yield Strength: 85,000

P.E. certified ratings include but are not limited to computer simulated torque and lifting analysis. These simulations allow our engineers and designers to identify and improve upon higher stress areas in our tools to ensure maximum production and safety.

Jeffrey Machine Casing Twisters are \*PE Certified.

# CONTINUOUS FLIGHT AUGERS (CFA'S)



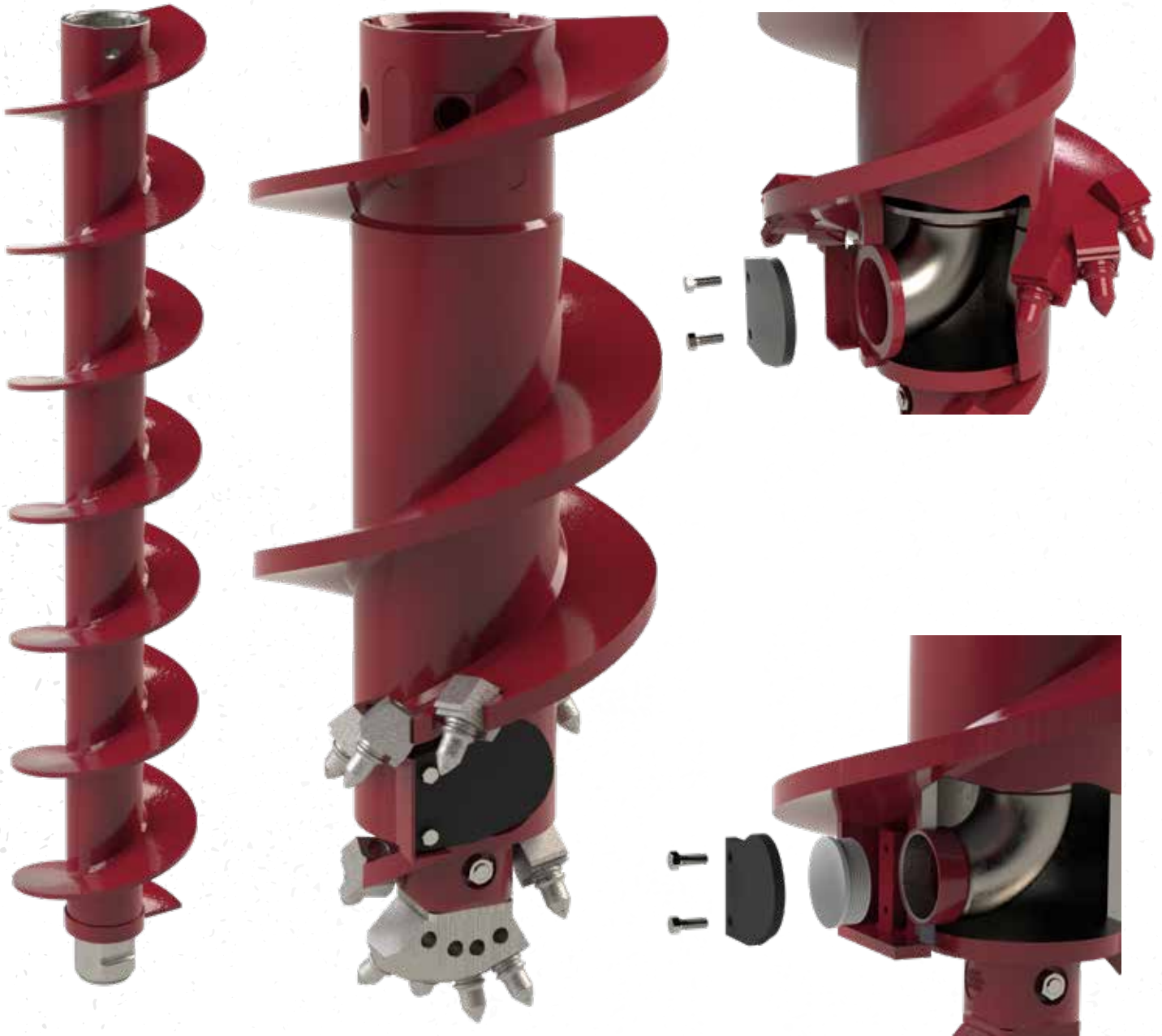

## CFA SPECIFICATIONS

**Commonly Requested Diameters:** 8" – 48" \*

**Cut:** DC/DF, DC/SF, SC/SF

**Grout Port:** Side discharge

**Type:** 3, 4, 5, 6

**Connections:**

- Spline & Hex Couplers
- API & ACME Threaded Couplers

**Cutter Head Length:** 5', 10', 20'

**Flight Body:** 5', 10', 20'

**Wear Protection or Hard Surface Options Available. SEE PAGE 12**

\* Custom sizes available upon request.

**SIZE 42 CORK**  
P/N 39200

**SIZE 44 CORK**  
P/N 39201

**SIZE 46 CORK**  
P/N 39202

**SIZE 48 CORK**  
P/N 39203



# SOIL MIXING TOOL

Shown as a 3-blade soil mixing tool.



Static Central Stabilizer

**NOTE:** Soil Mixing blades & supports are made from A514 / T1 material for increased wear, durability, and long-lasting strength. (A514 T1 - 110,000 -130,000 psi Tensile Strength)

Fixed Central Stabilizer

## SOIL MIXING TOOL SPECIFICATIONS

Commonly Requested Diameters: 18" – 144" \*

Drive Connections: Specified by customer

Combination of dirt teeth and dirt pilots available.

\* Custom sizes greater than 144" available upon request.



38mm Tri-Holder  
P/N 32064



X295 Holder  
P/N 36105



BFZ 100X70/2  
P/N 34172



X295 Tooth  
P/N 34405

# SPLINE COUPLERS

Coupler Assembly	Maximum Torque	Maximum Pull-Out Force
9.250in Spline Coupler	130,000 ft-lbs	1,040,000 lbs
11.000in Spline Coupler	262,000 ft-lbs	1,160,000 lbs
14.000in Spline Coupler	672,000 ft-lbs	1,550,000 lbs

**9.25" Spline Coupler Set**  
 Max. Torque: 130,000 ft-lbs  
 Max. Pull-Out Force: 1,040,000 lbs  
 P/N 27920



**9.25" Spline O Ring & Set Screw Kit**  
 P/N 27925

**11" Spline Coupler Set**  
 Max. Torque: 262,000 ft-lbs  
 Max. Pull-Out Force: 1,160,000 lbs  
 P/N 27930



**11" Spline O Ring & Set Screw Kit**  
 P/N 27935

**14" Spline Coupler Set**  
 Max. Torque: 672,000 ft-lbs  
 Max. Pull-Out Force: 1,550,000 lbs  
 P/N 27940



**14" Spline O Ring & Set Screw Kit**  
 P/N 27945

Jeffrey Machine manufactures CFA Spline Couplers, CFA Hex Couplers, ACME Threaded Couplers as well as API Couplers. We operate state-of-the-art machines at our Birmingham facility to provide a timely source of supply. This enables us to make customer requested modifications.

\*Male/female sold separately upon request.

\*PE Certified

# CFA HEX COUPLERS

Couplers and adapters are manufactured in-house to any shape or design required.

Coupler Assembly	Maximum Torque	Maximum Pull-Out Force
80mm Hex Coupler	19,300 ft-lbs	96,400 lbs
120mm Hex Coupler	65,000 ft-lbs	217,000 lbs
150mm ABI Hex Coupler	263,000 ft-lbs	805,000 lbs
160mm Hex Coupler	154,000 ft-lbs	386,000 lbs
200mm Hex Coupler	292,000 ft-lbs	560,000 lbs

**80mm Hex Coupler Set**  
 Torque: 19,300 ft-lbs  
 Max. Pull-Out Force: 96,400 lbs  
 P/N 27500

**80mm Hex Locking Pin Set**  
 P/N 27530



**120mm Hex Coupler Set**  
 Torque: 65,000 ft-lbs  
 Max. Pull-Out Force: 217,000 lbs  
 P/N 27570

**120mm Hex Locking Pin Set**  
 P/N 27600



**150mm ABI Hex Coupler Set**  
 Torque: 263,000 ft-lbs  
 Max. Pull-Out Force: 805,000 lbs  
 P/N 27850

**150mm Hex Locking Set Screw**  
 P/N 27853



**160mm Hex Coupler Set**  
 Torque: 154,000 ft-lbs  
 Max. Pull-Out Force: 386,000 lbs  
 P/N 27640

**160mm Hex Locking Pin Set**  
 P/N 27670



**200mm Hex Coupler Set**  
 Torque: 292,000 ft-lbs  
 Max. Pull-Out Force: 560,000 lbs  
 P/N 27710

**200mm Hex Locking Pin Set**  
 P/N 27740



\*PE Certified

# THREADED COUPLERS FOR CFA

Couplers and adapters are manufactured in-house to any shape or design required.



3" ACME Threaded Coupler Set  
P/N 27430



4" ACME Threaded Coupler Set  
P/N 27400

Other sizes available.

All Jeffrey Machine couplers are manufactured from alloy steel material for increased strength, weldability, and machinability. Due to the high carbon content of this alloy steel, special welding procedures are required to minimize cracks in the heat affected zones. Please contact your Jeffrey Machine Representative today if you have any questions regarding this procedure or would like any further information in reference to our extensive line of couplers.

# BOULDER EXTRACTORS

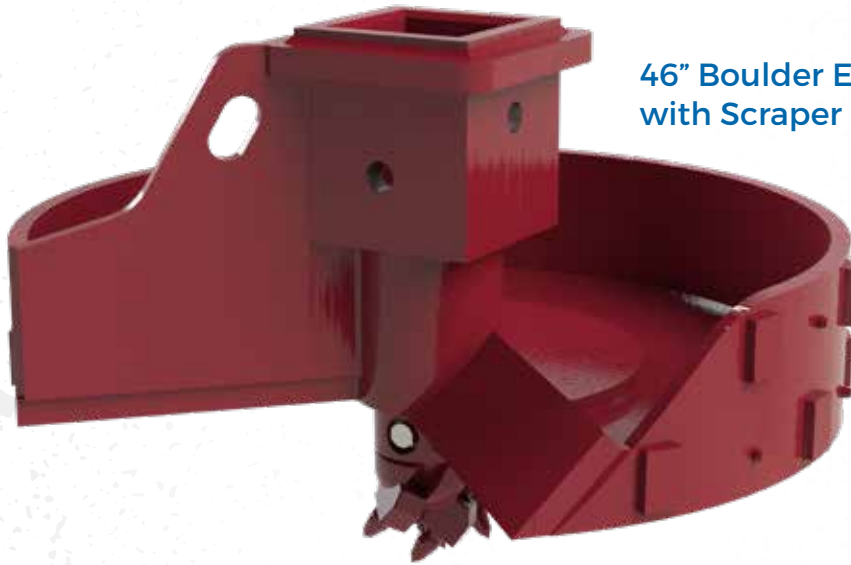

46" Boulder Extractor  
with Scraper



36" Boulder Extractor  
with .990



36" Boulder Extractor  
Pitched

## **BOULDER EXTRACTOR SPECIFICATIONS**

**Commonly Requested Diameters:** 16" – 144"

**Kelly boxes:** All kelly boxes made to customer specifications

**Flight Thickness:** 1½"

### **Options:**

- Pitched or Flat
- Rock or Dirt Pilot Optional

# AUGER HD REAMING ARMS

3" reaming arms increase the max total cut by 6" total. 6" reaming arms increase the max total cut by 12" total. **Only available for augers 72" and larger.**

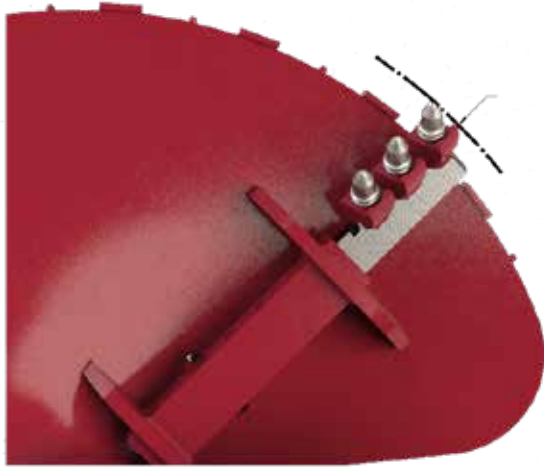

When the over cutter arm is set at the inner most adjustment the outside tooth will be cutting at the same diameter as the max cut of the auger.

## No extension

**6" HD 38mm Rock**

P/N 39354P

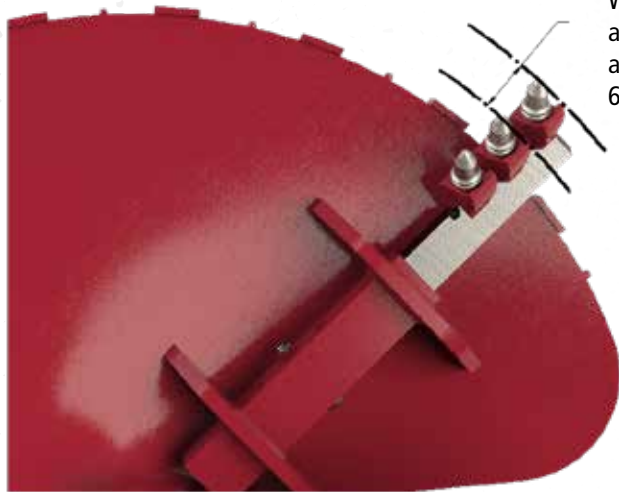

When the over cutter arm is set at the center adjustment the outside tooth will be cutting at 3" over the max cut of the auger. This will add 6" to the overall diameter of the auger.

## Increases max cut by 6"

**6" HD 38mm Rock**

P/N 39354P



When the over cutter arm is set at the center adjustment the outside tooth will be cutting at 6" over the max cut of the auger. This will add 12" to the overall diameter of the auger.

## Increases max cut by 12"

**6" HD 38mm Rock**

P/N 39354P

# AUGER STANDARD REAMING ARMS

Available for augers 30" or larger diameter.

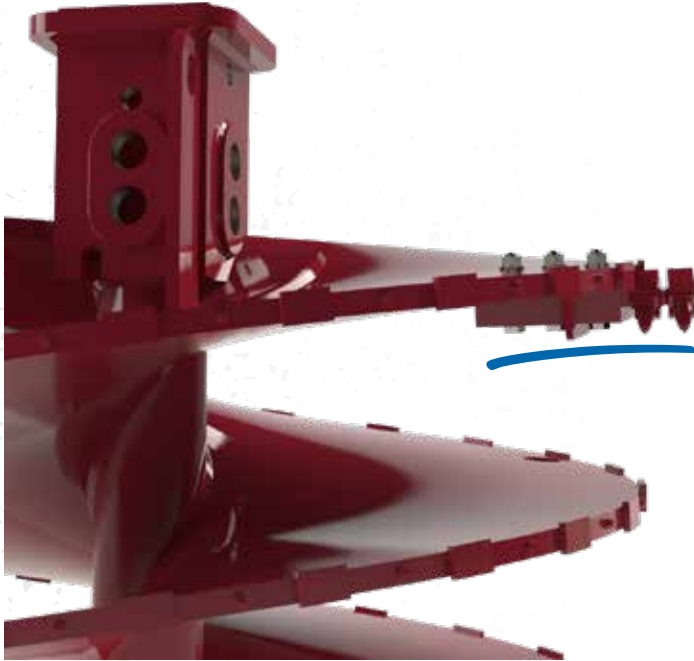

**3" Flat .990 Rock Reaming  
Arm W/ Hardware**  
P/N 39380

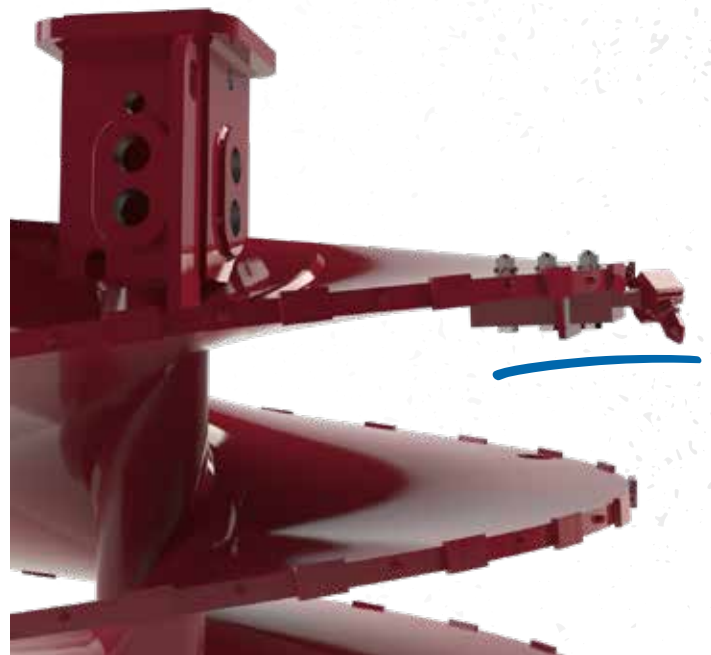

**3" Flat 38mm Rock  
Reaming Arm W/ Hardware**  
P/N 39383

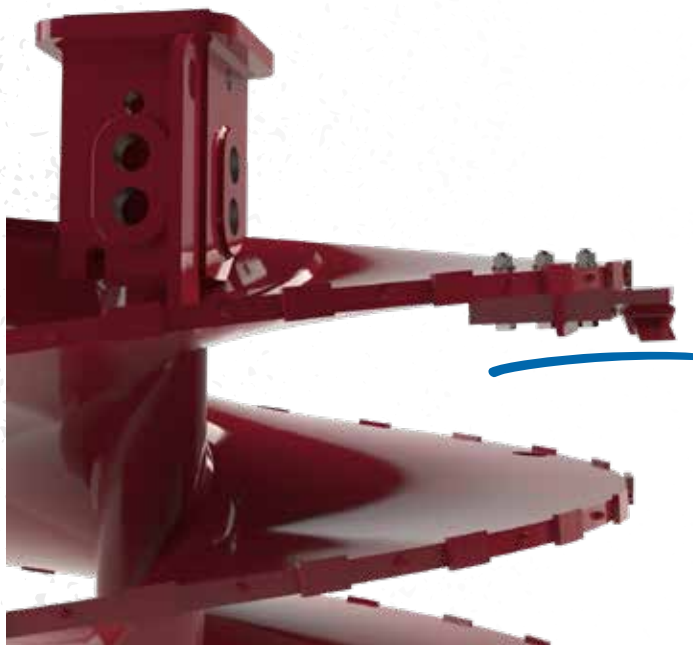

**3" Flat Dirt Tooth Reaming  
Arm W/ Hardware**  
P/N 39386

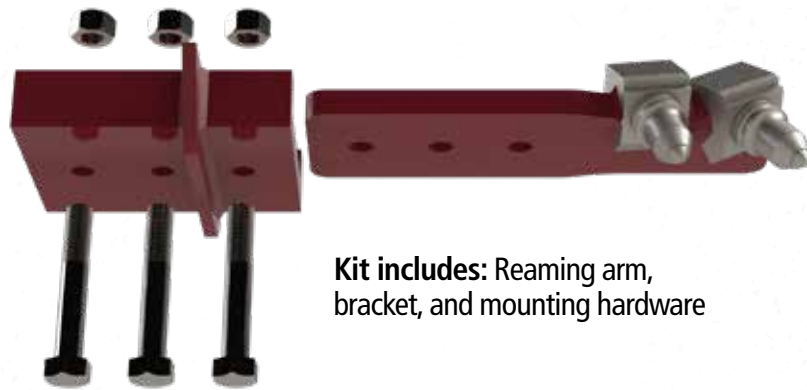

**Kit includes:** Reaming arm, bracket, and mounting hardware

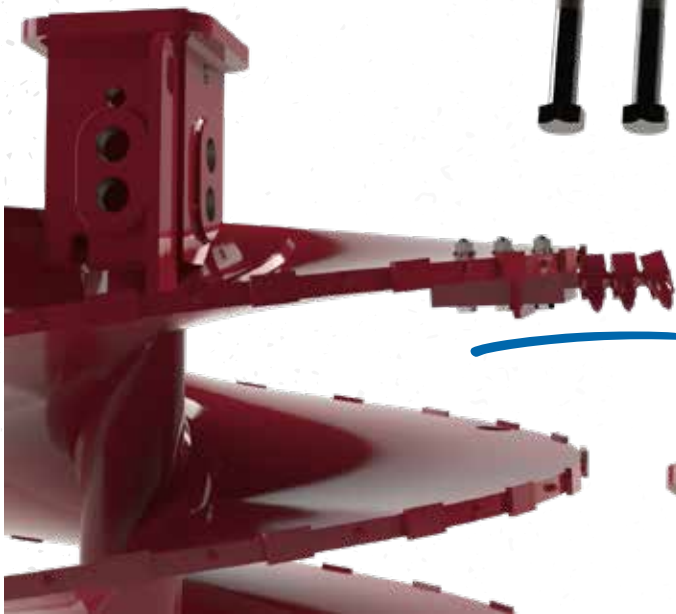

**6" Flat .990 Rock Reaming Arm W/ Hardware**  
P/N 39381

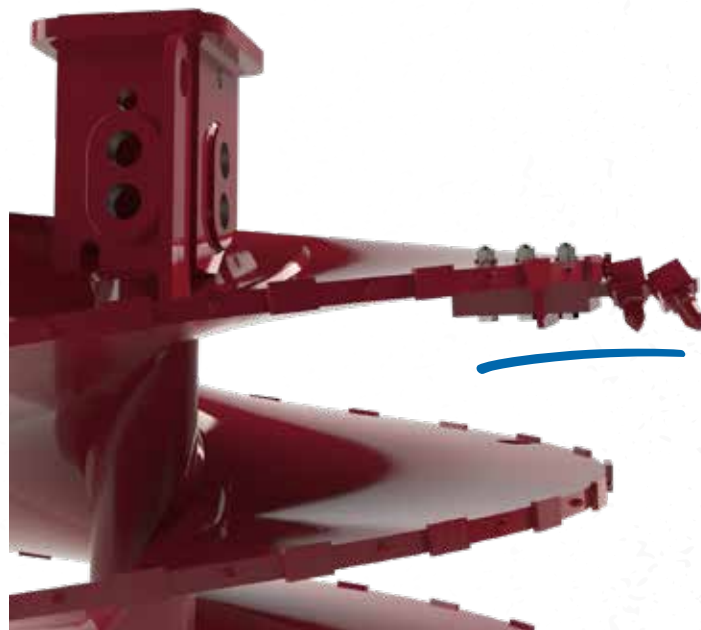

**6" Flat 38mm Rock Reaming Arm W/ Hardware**  
P/N 39384

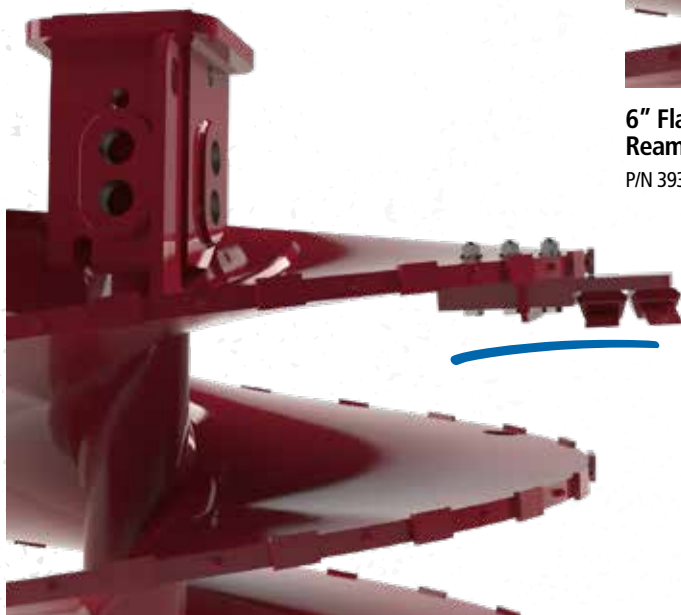

**6" Flat Dirt Tooth Reaming Arm W/ Hardware**  
P/N 39387





# CORE BARRELS & BUCKETS

**WE MANUFACTURE OUR  
CORE BARRELS AND  
BUCKETS ANY WAY YOU  
WANT.**

Although our factory has grown in size, we still maintain a machine shop mentality where every order is considered custom. As we've grown we've invested heavily in top-of-the-line machinery. These tools help us craft high quality solutions individually suited to our customers' needs on a timely basis.

By manufacturing everything in-house we have complete control of all aspects of design, quality, and cost.

# CORE BARRELS

Barrels over 60" are built with cross tops.



96" MC Core Barrel

Top View

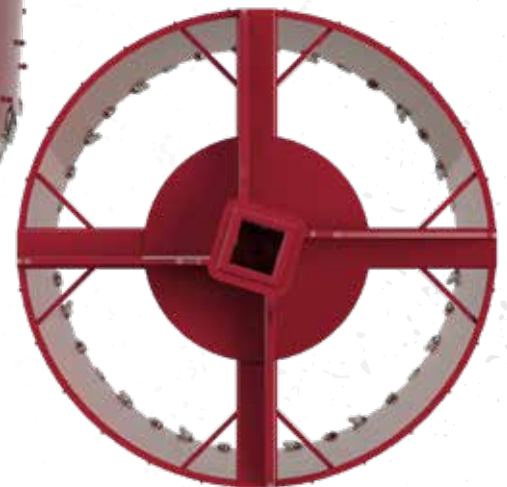

## CORE BARREL SPECIFICATIONS

**Commonly Requested Diameters:** 16" – 156"

**Kelly boxes:** All kelly boxes made to customer specifications

**Gussets:** 1" thick gussets standard

### Barrels:

- Up to 2" thick
- 2" undersize (.990 teeth)
- 3" undersize (38mm teeth)

**Height specified by customer**

**Wear Protection:** Available upon request

Hardened holders available upon request.



.990 JeffCut®  
Holder with:

B40HDS

.990HB

.990 Dragon's Tooth®



38mm JeffCut®  
Holder with:

38mm Dragon's Tooth®

BKH113

B47K22-H

B47K19L

B47K19H

Layout Pattern Options:

**3 TOOTH**



**5 TOOTH**



**7 TOOTH**



48" MC Core Barrel

Top View

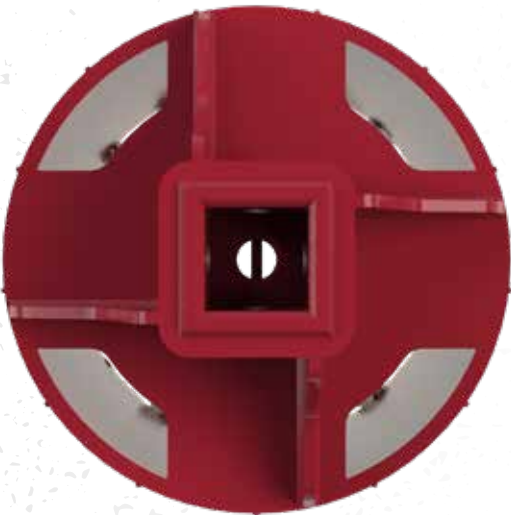

# ROLLER CONE BARREL

Best used on rock conditions over 14,500 psi.

Recommended minimum crowd is 10,000 lb. per roller.

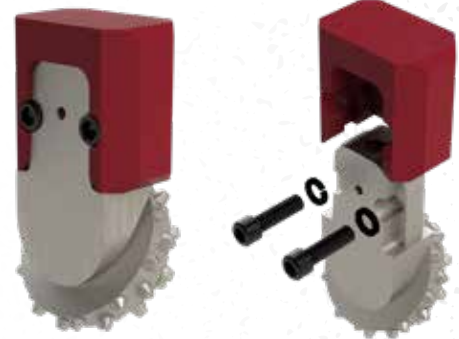

Quick Change 2 Bolt Roller Cone

P/N 39505

Quick Change 2 Bolt Roller Cone Holder

P/N 39506

## ROLLER CONE BARREL SPECIFICATIONS

Commonly Requested Diameters: 16" – 144"

Kelly boxes: All kelly boxes made to customer specifications

Gussets: 1" thick gussets standard

Barrels: Up to 2" thick

Height specified by customer

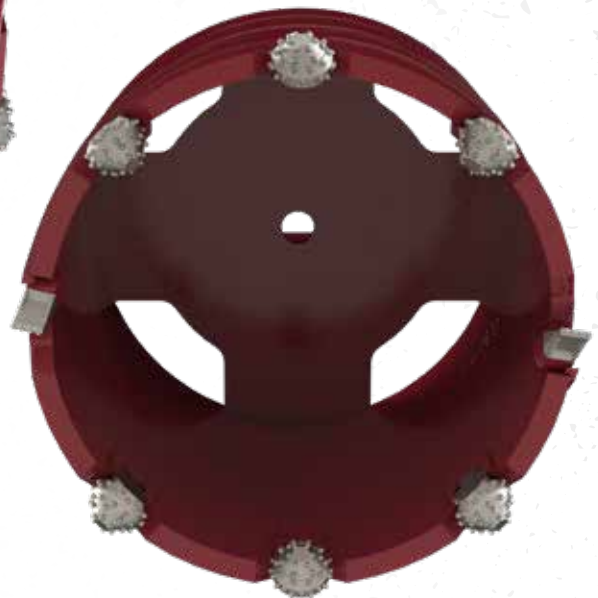



JEFFREY  
MACHINE INC  
PRECISION



JEFFREY  
MACHINE INC  
DRIVEN BY PRECISION

JEFFREYMACHINE.COM

# CORE RINGS & CUSTOM PLATE ROLLING



## CORE RINGS SPECIFICATIONS

Replacement core rings are available upon request, or can be ordered as a separate item. All core rings are quoted as a minimum of 12" overall height.

### Specifications needed to quote

- Max Cut requirement
- OD of existing barrel
- Tooth pattern: 3, 5, or 7
- Thickness of ring

### Custom Plate Rolling

- A-36 rated steel plate standard
- OD x ID x W Specifications needed to quote
- Diameters: 24" – 156"
- Thickness: up to 2" thick mild steel

# BELLING TOOL



NOMINAL SIZE		
Dia.	Bell Dia.	Angle
12	36	45° or 60°
14	42	45° or 60°
16	48	45° or 60°
18	54	45° or 60°
20	60	45° or 60°
24	72	45° or 60°
30	90	45° or 60°
36	108	45° or 60°
42	126	45° or 60°
48	144	45° or 60°
54	162	45° or 60°
60	180	45° or 60°
66	198	45° or 60°
72	216	45° or 60°

Belling tool wings & wing supports are made from A514 / T1 material for increased wear, durability, and long-lasting strength. (A514 T1 - 110,000 -130,000 psi Tensile Strength)



## BELLING TOOL SPECIFICATIONS

Available sizes: 12"–72"

### Wings:

- 3:1 ratio of cylinder
- 45 or 60 degree
- T1 Material

### Most Commonly Used Teeth:

- .990 series
- 201 dirt teeth



201 Dirt Tooth  
P/N 34100



.990 Dragon's Tooth®  
P/N 30145



.990 Dirt Tooth  
P/N 34380



.990HB  
P/N 30122



B40 HDS  
P/N 30155

\*Barrel diameters are actual sizes.

Replacement dump mechanism parts available. Ref. Page 56 for more information.

# CROSS-CUT CORE BARRELS

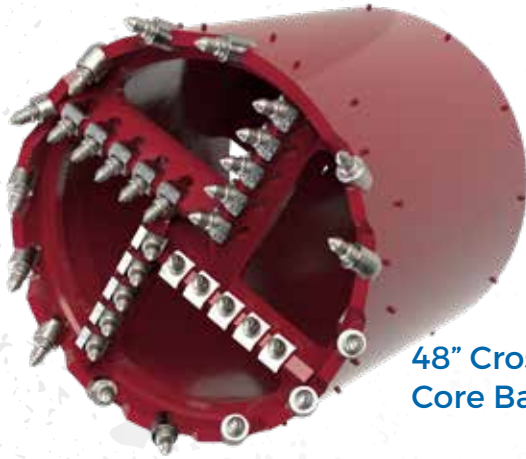

48" Cross-Cut Core Barrel

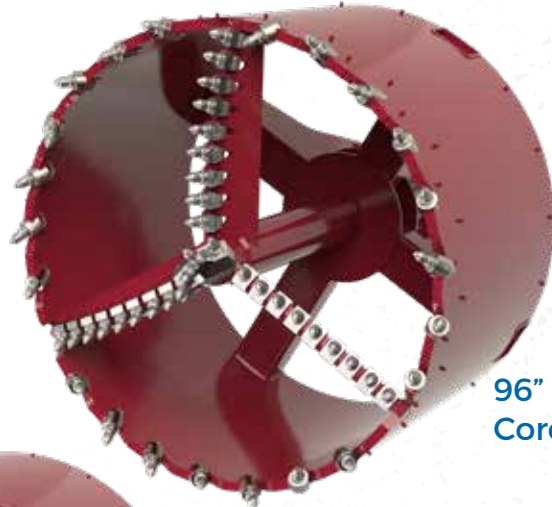

96" Cross-Cut Core Barrel



82" Cross-Cut Core Barrel

Cross-Cut cutter bars are made from A514 / T1 material for increased wear, durability, and long-lasting strength. (A514 T1 - 110,000 -130,000 psi Tensile Strength)

## CROSS-CUT CORE BARREL SPECIFICATIONS

**Commonly Requested Diameters:** 20" – 144"

**Kelly boxes:** All kelly boxes made to customer specifications

**Gussets:** 1" thick gussets standard

**Barrels:**

- Up to 2" thick
- 2" undersize (.990 teeth)
- 3" undersize (38mm teeth)

**Cutter Bar:** .990 or 38mm options available

**Cutter Bar Material:** A514 T1 (110,000- 130,000 psi Tensile Strength)

**Height specified by customer**

**Wear Protection:** Available upon request



B47K19L  
P/N 30182



55-1S / C4-1  
P/N 30242



38mm Dragon's Tooth® Holder  
P/N 32058



.990 Dragon's Tooth®  
P/N 30145



.990 Dragon's Tooth® Holder  
P/N 32049

## TEETH & HOLDERS FOR OUTSIDE DIAMETER



.990 JeffCut®  
Holder with:



B40HDS



.990HB



.990 Dragon's Tooth®



38mm JeffCut®  
Holder with:



38mm Dragon's Tooth®



BKH113



B47K22-H



B47K19L



B47K19H

# ROCK MILLS

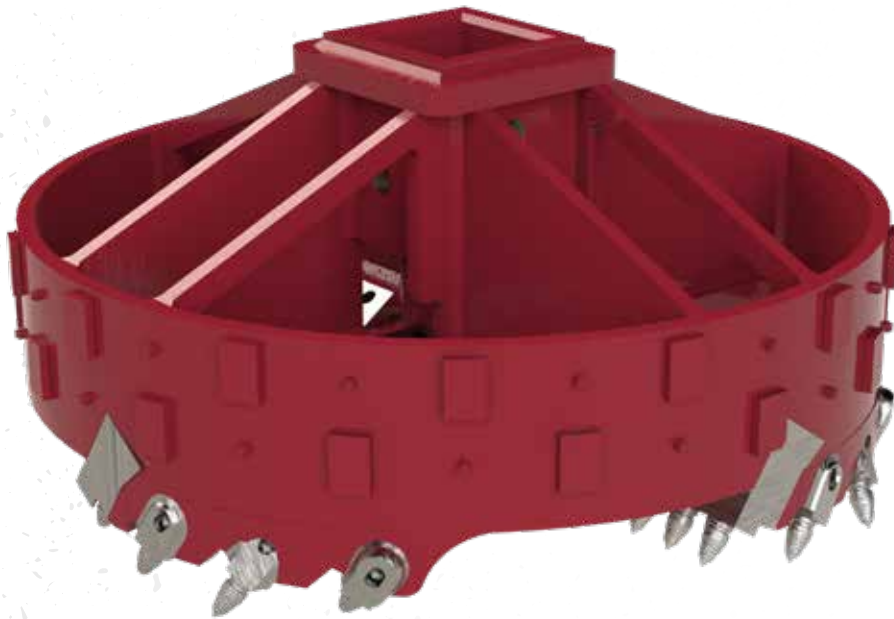

**.990HB**  
P/N 30122



**B47K19L**  
P/N 30182

## ROCK MILL SPECIFICATIONS

**Diameters:** 24"–144"

**Ring:** 1" thick

**Cutter Bar:** 4140 Annealed  
(95,000 psi Tensile Strength)

**Teeth:** Double row configuration:

- .990 Standard (30122)
- 38mm B47K19LK80-H (30182)

**Wear Protection:**  
2" x 3" x 1/2" wear pads (39302)



Machined cutter bars for our Rock Mills are manufactured from 4140 Annealed material for increased strength and machinability. (4140 Annealed - 95,000 psi Tensile Strength)

# SINGLE OPEN DIRT DRILLING BUCKET



Arrowhead



Exploded View



J-Hook

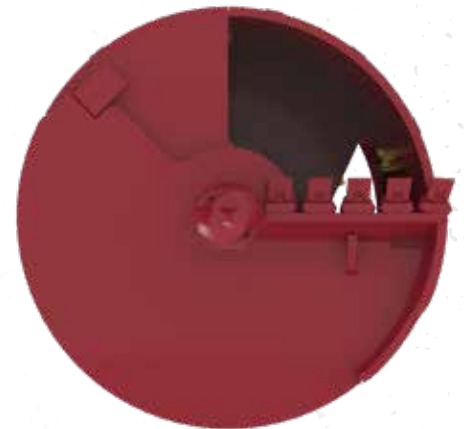

Bottom View

## SINGLE OPEN DIRT DRILLING BUCKET SPECIFICATIONS

**Recommended Diameters:** 24" – 60"

**Kelly boxes:** All kelly boxes made to customer specifications

**Barrels:** Cylinders up to 2" wall available

Barrels undersized to meet max cut specifications

**Barrel height:** Specified by customer

**Barrel details:** See page 58 for material specifications and pin-on options.

Dump Bottom System (Auto or Manual)

Custom sizes greater than 144" available upon request.



201 Dirt Tooth  
P/N 34100



WO-5 Holder  
P/N 36010



2.5" SQ. JM-08 Dirt Pilot  
P/N 40470



4" SQ. JM 8" Dirt Pilot  
P/N 40260

# DOUBLE OPEN DIRT DRILLING BUCKET



Exploded View

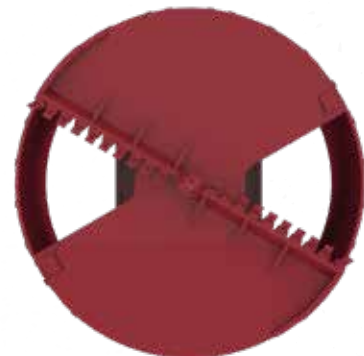

Bottom View



Arrowhead Single



Arrowhead Double



J-Hook Single



J-Hook Double

## DOUBLE OPEN DIRT DRILLING BUCKET SPECIFICATIONS

**Recommended Diameters:** 60" – 144"

**Kelly boxes:** All kelly boxes made to customer specifications

**Barrels:** Cylinders up to 2" wall available

Barrels undersized to meet max cut specifications

**Barrel height:** Specified by customer

**Barrel details:** See page 58 for material specifications and pin-on options.

Dump Bottom System (Auto or Manual)

Custom sizes greater than 144" available upon request.

*Double dump mechanism recommended on barrels 100" diameter and greater.*



201 Dirt Tooth  
P/N 34100



WO-5 Holder  
P/N 36010



2.5" SQ. JM-08 Pilot  
P/N 40470



4" SQ. JM 8" Dirt Pilot  
P/N 40260

\*Not all drive boxes available on all sizes. Please contact us to find out if a particular drive box will fit in this application.

# SINGLE OPEN ROCK DRILLING BUCKET



Bottom View

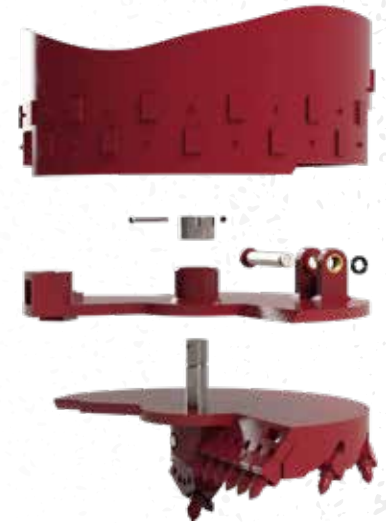

Exploded View



Arrowhead



J-Hook



Manual

## SINGLE OPEN ROCK DRILLING BUCKET SPECIFICATIONS

**Recommended Diameters:** 24" – 60"

**Kelly boxes:** All kelly boxes made to customer specifications

**Barrels:** Cylinders up to 2" wall available

Barrels undersized to meet max cut specifications

**Barrel height:** Specified by customer

**Barrel details:** See page 58 for material specifications and pin-on options.

Dump Bottom System (Auto or Manual)



**.990HB**  
P/N 30122



**B47K19L**  
P/N 30182



**.990 Dragon's Tooth®**  
P/N 30145



**38mm Dragon's Tooth®**  
P/N 30188



**.990 Tri-Holder**  
P/N 32042



**38mm Tri-Holder**  
P/N 32064



**2.5" SQ. .990 Pilot**  
P/N 40205



**RP-4 Machined Pilot**  
P/N 40285



**BFZ 100X70/2**  
P/N 34172

# DOUBLE OPEN ROCK DRILLING BUCKET

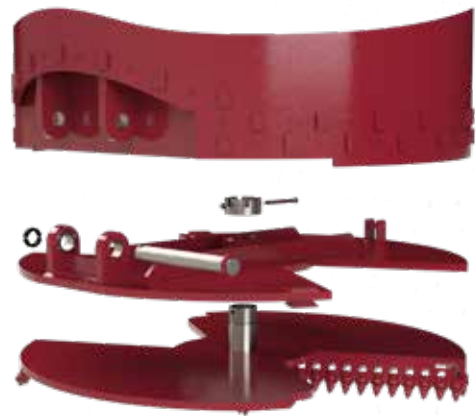

Exploded View



Arrowhead Single



Arrowhead Double



J-Hook Single



J-Hook Double



Bottom View

## DOUBLE OPEN ROCK DRILLING BUCKET SPECIFICATIONS

**Recommended Diameters:** 60" – 144"

**Kelly boxes:** All kelly boxes made to customer specifications

**Barrels:** Cylinders up to 2" wall available

Barrels undersized to meet max cut specifications

**Barrel height:** Specified by customer

**Barrel details:** See page 58 for material specifications and pin-on options.

Dump Bottom System (Auto or Manual)

Custom sizes greater than 144" available upon request.

*Double dump mechanism recommended on barrels 100" diameter and greater.*



**.990HB**  
P/N 30122



**B47K19L**  
P/N 30182



**.990 Dragon's Tooth®**  
P/N 30145



**38mm Dragon's Tooth®**  
P/N 30188



**.990 Tri-Holder**  
P/N 32042



**38mm Tri-Holder**  
P/N 32064



**2.5" SQ. .990 Pilot**  
P/N 40205



**RP-4 Machined Pilot**  
P/N 40285



**BFZ 100X70/2**  
P/N 34172

# HD DRILLING BUCKET CUTTER BAR STYLE

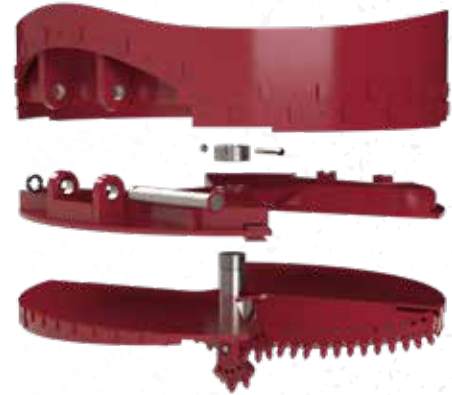
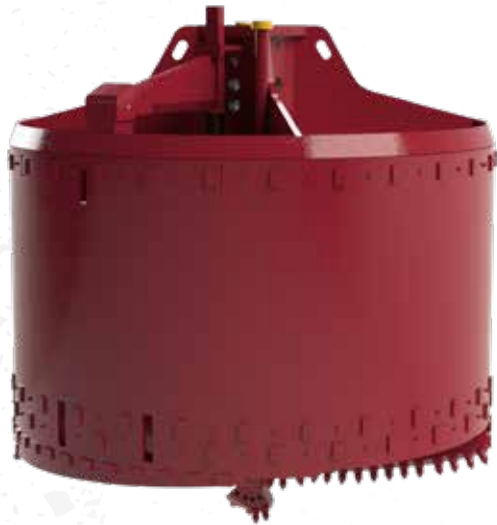

*Exploded View*



*Bucket Bottom*



*Open View*

## HD DRILLING BUCKET CUTTER BAR STYLE SPECIFICATIONS

**Diameters:** 60" – 144"

**Kelly boxes:** All kelly boxes made to customer specifications

**Barrels:** Cylinders up to 2" wall available

Barrels undersized to meet max cut specifications

**Barrel height:** Specified by customer

**Barrel details:** See page 58 for material specifications and pin-on options.

Dump Bottom System (Auto or Manual)

Custom sizes greater than 144" available upon request.



**B47K19L**  
P/N 30182



**38mm Dragon's Tooth®**  
P/N 30188



**38mm Tri-Holder**  
P/N 32064



**RP-4 Machined Pilot**  
P/N 40285

# TAPERED BOTTOM DRILLING BUCKET

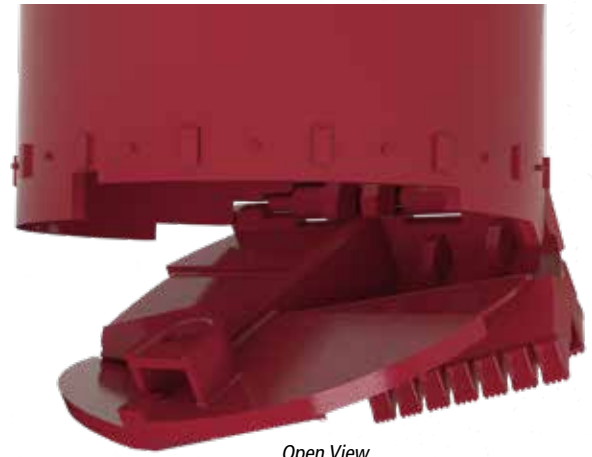

Open View

Tapered bottom drilling buckets are designed to trap spoil using a simple hinged door that opens while down pressure is being applied. Emptying the bucket is hassle free with our automatic or manual dumping mechanism. For more information contact one of our sales representatives today.

## TAPERED BOTTOM DRILLING BUCKET SPECIFICATIONS

**Commonly Requested Diameters:** 36" – 144"

**Kelly boxes:** All kelly boxes made to customer specifications

**Barrels:** Cylinders up to 2" wall available

Barrels undersized to meet max cut specifications

**Barrel height:** Specified by customer

Dump Bottom System (Auto or Manual)

Custom sizes greater than 144" available upon request.



BFZ 100X70/2  
P/N 34172

# SINGLE OPEN CLEAN OUT BUCKET

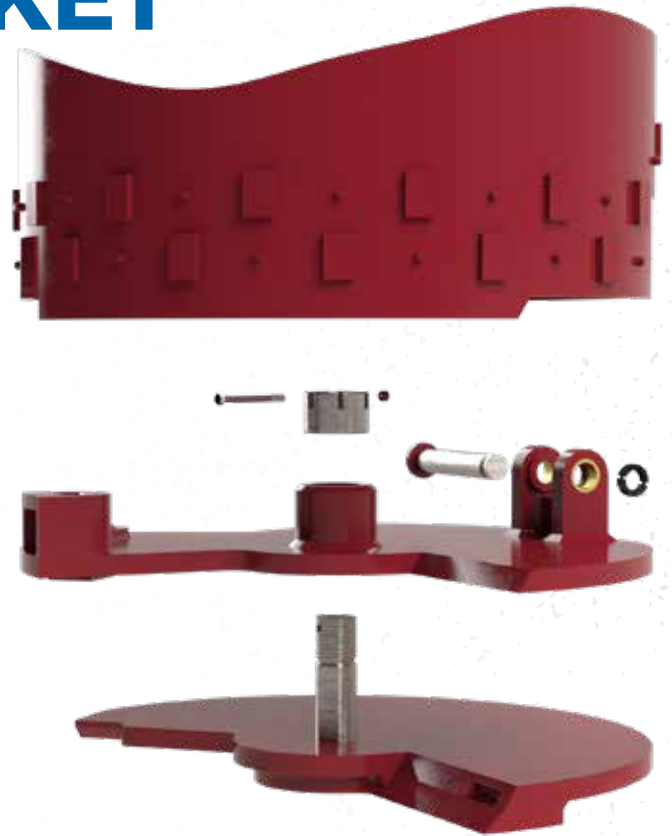

*Exploded View*



*Flat Bottom View*

## **SINGLE OPEN CLEAN OUT BUCKET SPECIFICATIONS**

**Recommended Diameters:** 24" – 60"

**Kelly boxes:** All kelly boxes made to customer specifications

**Barrels:** Cylinders up to 2" wall available

Barrels undersized to meet max cut specifications

**Barrel height:** Specified by customer

**Barrel details:** See page 58 for material specifications and pin-on options.

Dump Bottom System (Auto or Manual)

# DOUBLE OPEN CLEAN OUT BUCKET

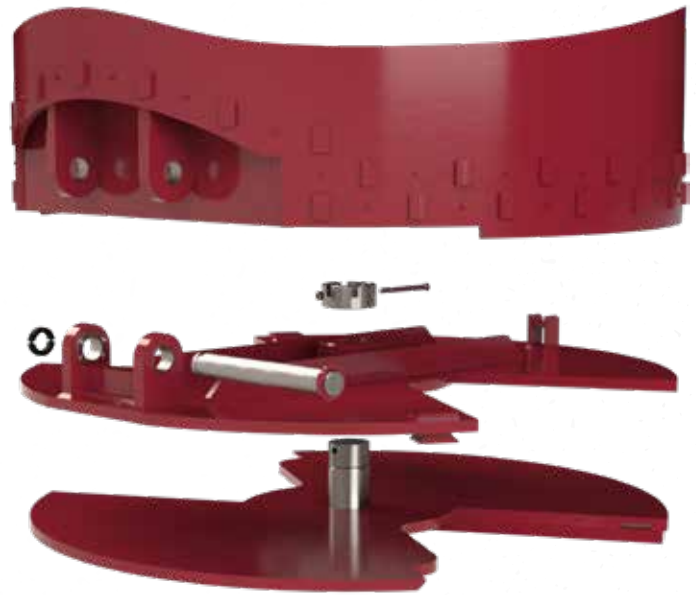

*Exploded View*

## DOUBLE OPEN CLEAN OUT BUCKET SPECIFICATIONS

**Recommended Diameters:** 60" – 144"

**Kelly boxes:** All kelly boxes made to customer specifications

**Barrels:** Cylinders up to 2" wall available

Barrels undersized to meet max cut specifications

**Barrel height:** Specified by customer

**Barrel details:** See page 58 for material specifications and pin-on options.

Dump Bottom System (Auto or Manual)

Custom sizes greater than 144" available upon request.

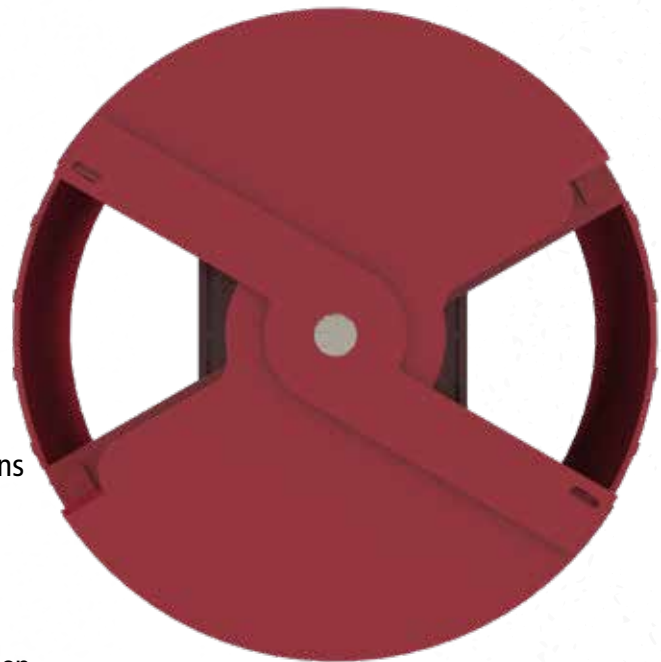

*Flat View - Bottom*

# DRILLING BUCKET PARTS

## ARROWHEAD DUMP ASSEMBLY



**Arrowhead Male**  
LARGE P/N 10865  
MEDIUM P/N 10864  
SMALL P/N 10863



**Clevis End**  
P/N 10899 & 10900



**Plunger Cap**  
P/N 10890



**Plunger Pin**  
P/N 10892 & 10894



**Plunger Shaft**  
P/N 10891 & 10893



**Plunger Spring**  
P/N 10895



**Plunger Tube**  
P/N 10889



**Pull Handle Receiver**  
P/N 10867 & 10886



**Slide Wedge**  
P/N 10896, 10897, 10898 & 10901



**Spring**  
P/N 10883

## ARROWHEAD FEMALE



## HINGES



**Barrel Hinge Plates**  
LARGE P/N 10841 & 10845  
MEDIUM P/N 10840 & 10843



**Bottom Hinge Plates Large**  
P/N 10813 & 10814



**Bottom Hinge Plates Medium**  
P/N 10811 & 10812



**Hinge Assembly - Small**



**Hinge Pin**

## J-HOOK DUMP ASSEMBLY



**Guide Sleeve**  
P/N 10918

**Hook**  
P/N 10920

**Hook Pin**  
P/N 10919 & 10925

**Hook Shaft**  
P/N 10917

**Plunger Pin**  
P/N 10909 & 10916

**Plunger Shaft**  
P/N 10908 & 10938

**Plunger Spring**  
P/N 10914

**Plunger Tube**  
P/N 10906

## J HOOK LATCH ASSEMBLY

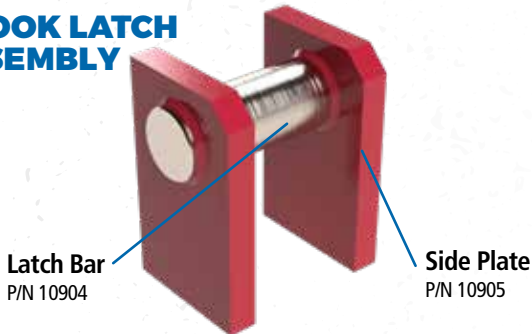

**Latch Bar**  
P/N 10904

**Side Plate**  
P/N 10905



**Wrench for Spin Bottom Pin Assembly**  
LARGE P/N 10838  
MEDIUM P/N 10837

## SPIN BOTTOM PIN ASSEMBLY

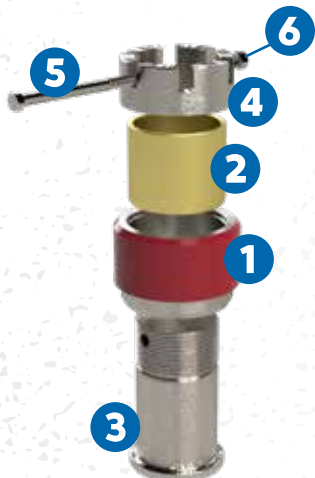

ITEM	LARGE P/N	MEDIUM P/N	SMALL P/N
1 Boss	10819	10818	10817
2 Manganese Bronze Bushing	10822	10821	10820
3 Spin Bottom Pin	10825	10824	10823
4 Castle Nut	10828	10827	10826
5 Hex Bolt	10831	10830	10829
6 Hex Nut	10834	10833	10832

# DRILLING BUCKET PARTS

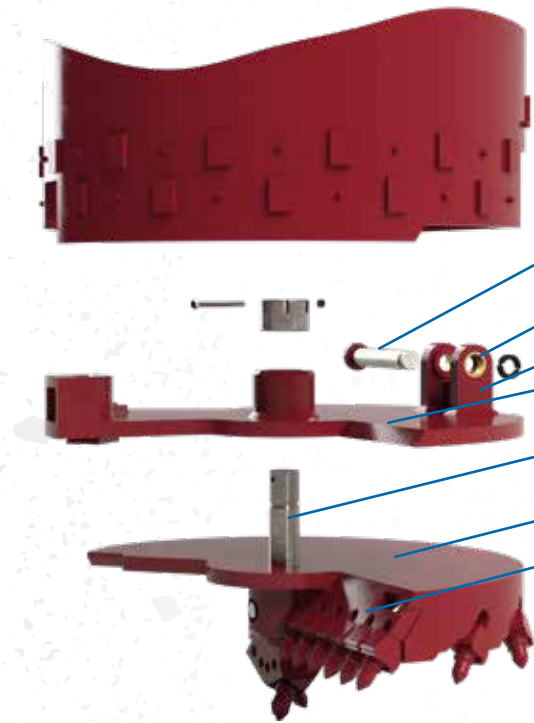

## ROCK DRILLING BOTTOM

- Hinge Pin – *High Strength Alloy*
- Hinge Bushings – *Manganese Bronze*
- Hinge Plates – *A514 T1*
- Mid Plate – *A572 GR50*
- Spin Bottom Pin – *4140 Annealed*
- Bottom Plate – *A572 GR50*
- Cutter Bar – *A514 T1*

## DIRT DRILLING BOTTOM

- Spin Bottom Pin – *4140 Annealed*
- Bottom Plate – *A572 GR50*
- Dirt Cutter Bar - *A514 T1*

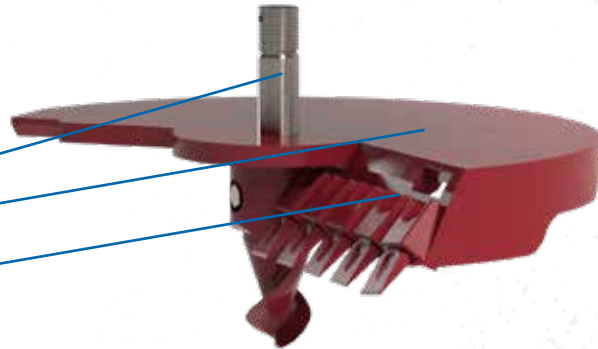

## CLEAN OUT BOTTOM

- Spin Bottom Pin – *4140 Annealed*
- Bottom Plate – *A572 GR50*
- Scraper Blade – *A514 T1*

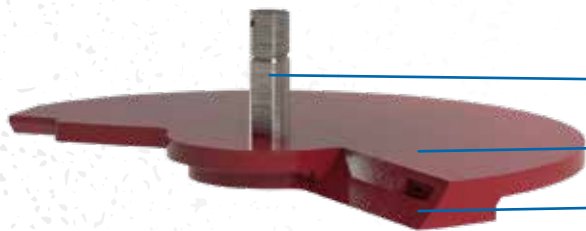

Material Grade	Tensile Strength
<i>A572 GR50</i>	<b>58,000 – 80,000 psi</b>
<i>A514 T1</i>	<b>110,000 – 130,000 psi</b>
<i>4140 Annealed</i>	<b>95,000 psi</b>
<i>High Strength Alloy</i>	<b>175,000 psi</b>
<i>Manganese Bronze</i>	<b>66,700 psi</b>

*Pin-on style bottoms allow any of the three options shown above to be used with the same JM bucket. Please contact a Jeffrey Machine Representative with any questions regarding our Drilling & Cleanout Buckets.*



# OPEN TOP SPIN BOTTOM CLEAN OUT BUCKET



## OPEN TOP SPIN BOTTOM CLEAN OUT BUCKET SPECIFICATIONS

**Commonly Requested Diameters:** 24" – 144" \*

**Kelly boxes\*\*:** All kelly boxes made to customer specifications

**Barrels:** Up to 2" thick

**Barrel height specified by customer**

**Top Plate:** 1" thick material with 1" gussets

- Double stop
- Solid center shaft
- 1½" T-1 scraper blade

**Wear Protection:** Available upon request

\*Custom sizes greater than 144" available upon request



*Bottom View*

\*\*Not all drive boxes available on all sizes. Please contact us to find out if a particular drive box will fit in this application.

# TWIST-LOCK RETRIEVAL BUCKET



## TWIST-LOCK RETRIEVAL BUCKET SPECIFICATIONS

Available sizes: 24" – 120"

## TEETH & HOLDERS FOR OUTSIDE DIAMETER



.990 JeffCut®  
Holder with:



B40HDS



.990HB



.990 Dragon's Tooth®



38mm JeffCut®  
Holder with:



38mm Dragon's Tooth®



BKH113



B47K22-H



B47K19L



B47K19H



JEFFERSON  
MACHINE  
206-841-8600

# DRIVE BOXES

## FABRICATED DRIVE BOX RATINGS

Drive Box	Standard Pin Diameter	Maximum Torque	Maximum Pull-Out Force
3.000in Drive Box	7/8"	40,800 ft-lbs	54,100 lbs
3.500in Drive Box	7/8"	52,500 ft-lbs	54,100 lbs
4.000in Drive Box	7/8"	65,500 ft-lbs	54,100 lbs
4.250in Drive Box	1"	123,000 ft-lbs	70,700 lbs
4.500in Drive Box	1"	135,000 ft-lbs	110,000lbs
5.000in Drive Box	1 1/2"	160,000 ft-lbs	159,000lbs
5.250in Drive Box	1 1/2"	174,000 ft-lbs	159,000lbs
6.000in Drive Box	1 1/2"	217,000 ft-lbs	159,000lbs
7.000in Drive Box	(2x) 1 1/2"	284,000 ft-lbs	(Double Pin) 318,000lbs
130mm Drive Box	1 1/2"	167,000 ft-lbs	159,000lbs
150mm Drive Box	1 3/4"	210,000 ft-lbs	216,000lbs
200mm Drive Box 18in Short Hole	2 3/8"	359,000 ft-lbs	(Double Pin) 797,000lbs
200mm Drive Box HD 18in Short Hole	2 3/8"	511,000 ft-lbs	(Double Pin) 797,000lbs
200mm Drive Box 18in Tall Hole	2 3/8"	359,000 ft-lbs	(Double Pin) 797,000lbs
200mm Drive Box HD 18in Tall Hole	2 3/8"	511,000 ft-lbs	(Double Pin) 797,000lbs
200mm Drive Box 21.500in	2 3/8"	359,000 ft-lbs	(Double Pin) 797,000lbs
200mm Drive Box HD 21.500in	2 3/8"	511,000 ft-lbs	(Double Pin) 797,000lbs

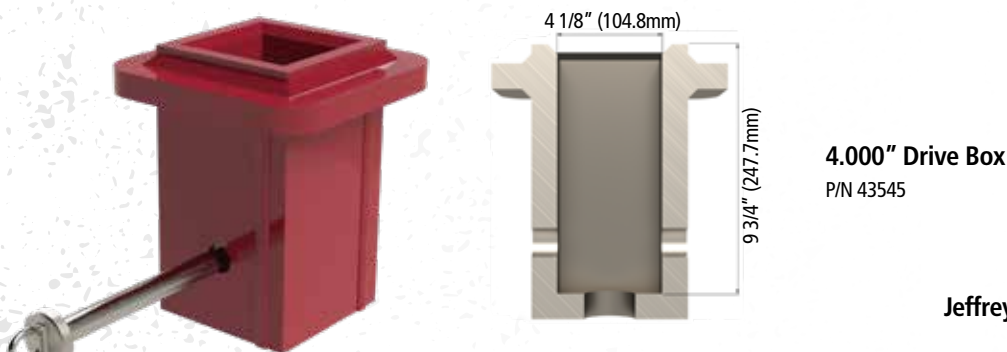
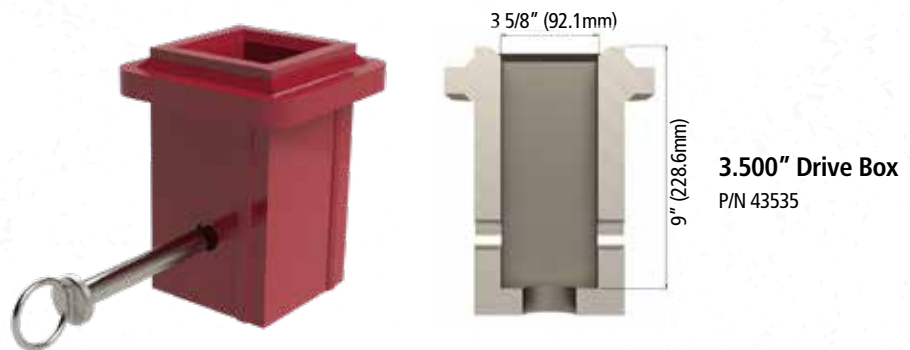

Jeffrey Machine Drive Boxes are \*PE Certified.

# DRIVE BOXES

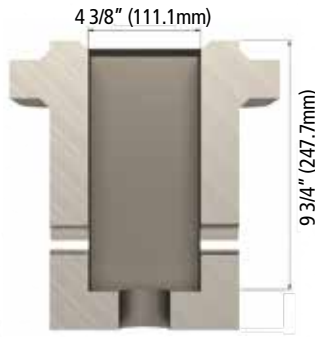

**4.250" Drive Box**  
P/N 43555



**4.500" Drive Box**  
P/N 43680

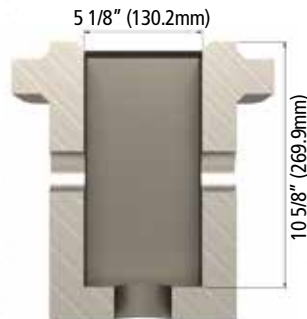

**5.000" Drive Box**  
P/N 43560

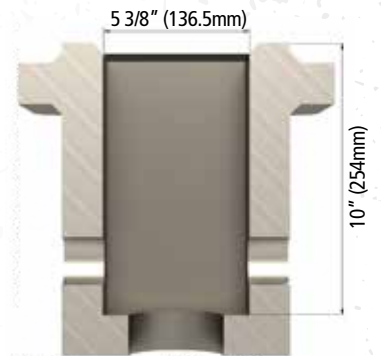

**5.250" Drive Box**  
P/N 43575

Jeffrey Machine Drive Boxes are \*PE Certified.

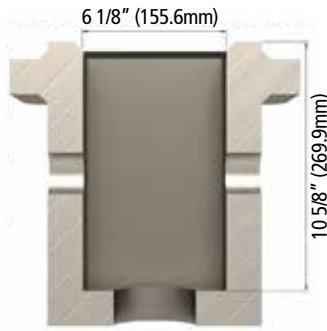

**6.000" Drive Box**  
P/N 43600



**7.000" Drive Box**  
P/N 43615

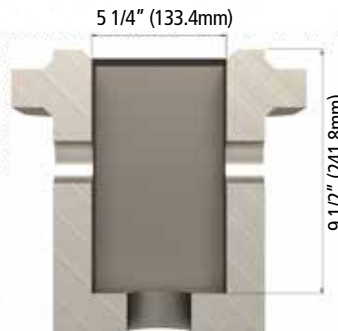
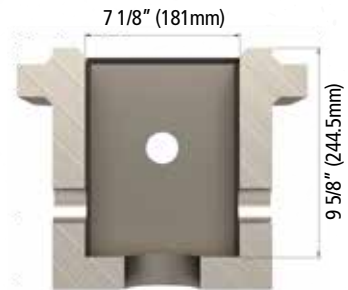

**130mm Drive Box**  
P/N 43595



**150mm Drive Box**  
P/N 43695

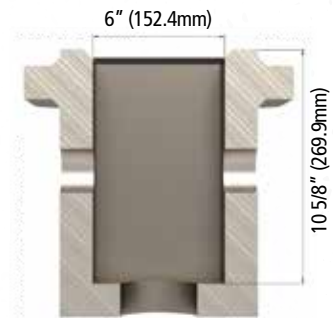

Jeffrey Machine Drive Boxes are \*PE Certified.

[JEFFREYMACHINE.COM](http://JEFFREYMACHINE.COM)

# DRIVE BOXES

**200mm Drive Box  
Short Hole 18"**  
P/N 43671

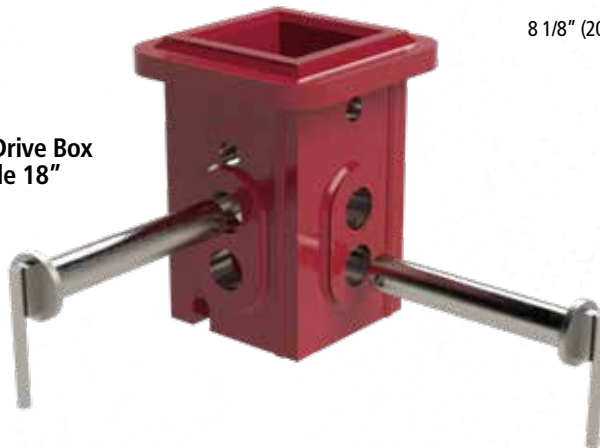

8 1/8" (206.4mm)

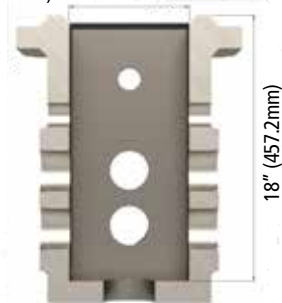

18" (457.2mm)

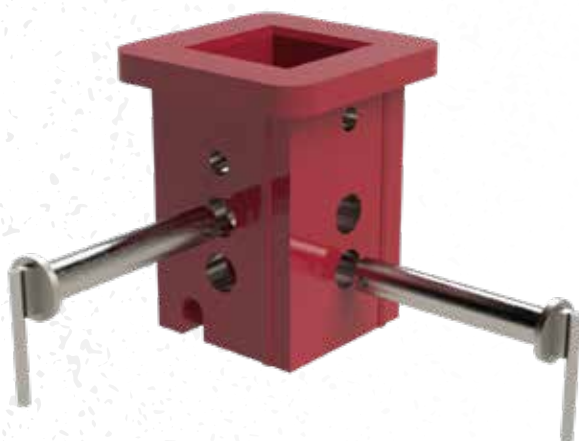

8 1/8" (206.4mm)



18" (457.2mm)

**200mm Drive Box  
HD Short Hole 18"**  
P/N 43677

**200mm Drive Box  
Tall Hole 18"**  
P/N 43670



8 1/8" (206.4mm)



18" (457.2mm)



8 1/8" (206.4mm)



18" (457.2mm)

**200mm Drive Box  
HD Tall Hole 18"**  
P/N 43676

Jeffrey Machine Drive Boxes are \*PE Certified.

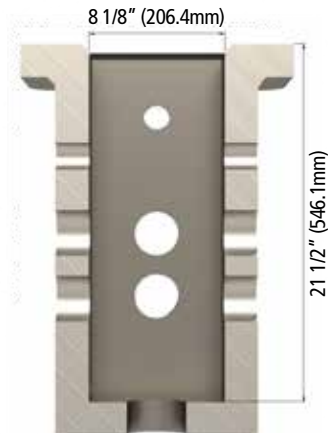
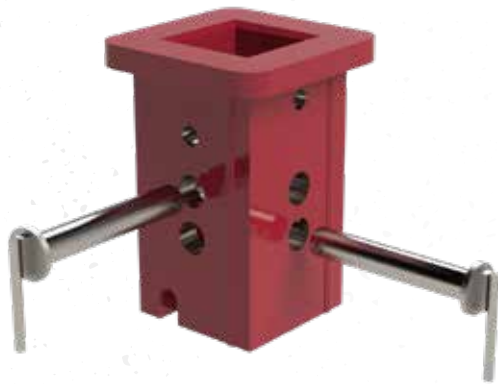

**200mm Drive Box  
HD 21.5"**  
P/N 43679

**200mm Drive Box  
21.5"**  
P/N 43678

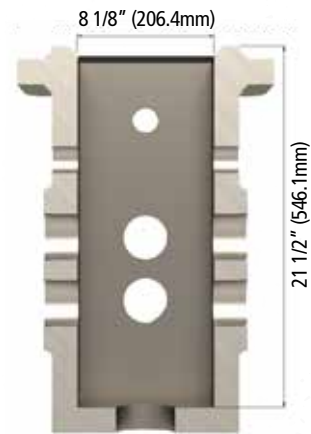
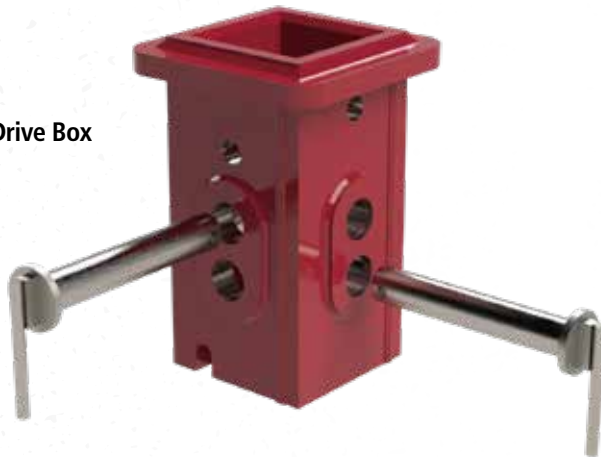

## DRIVE BOX ADAPTERS



**5.000in Drive Box  
to 4.000in Sq. Male  
Adapter**  
P/N 28500DBX400SM



**200mm Drive Box  
to 7.000in Sq. Male  
Adapter**  
P/N 28200DBX700SM

ADAPTER DISCLAIMER: This adapter exceeds the torque rating. Failure can and may occur. Jeffrey Machine will not be held responsible for failure due to over torque. Jeffrey Machine reserves the right to inspect if failure occurs.

Jeffrey Machine Drive Boxes are \*PE Certified.

JEFFREYMACHINE.COM



**KURT**  
KURTWORKHOLDING.COM

# SHIM BOXES

If you have multiple size kelly bars you can buy 1 tool and 3 shim boxes instead of buying 4 different tools.

Part Number	Description
98525X350SB	5-1/4" to 3-1/2" SHIM BOX
98525X400SB	5-1/4" to 4" SHIM BOX
98525X425SB	5-1/4" to 4-1/4" SHIM BOX
98700X130SB	7" to 130mm SHIM BOX
98700X525SB	7" to 5-1/4" SHIM BOX
98700X600SB	7" to 6" SHIM BOX
98200SX700SB	200mm to 7" SHIM BOX
98200TX700SB	200mm TALL SHIM BOX



**7" to 130mm Shim Box**  
P/N 98700X130SB



**200mm to 7" Shim Box**  
P/N 98200SX700SB



**SHIM BOX CLAUSE:** Shim boxes are made to fit Jeffrey Machine manufactured Kelly Drive boxes. Our shim boxes are fabricated then machined for a precise fit. Jeffrey Machines shim boxes are not guaranteed to fit in other manufactures boxes, for true measurements on shims please contact one of our sales representatives for more information.



## .990 Teeth



**.990 Dragon's Tooth®**  
P/N 30145



**B40 HDS**  
P/N 30155



**.990HB Conical Tooth**  
P/N 30122



**.990 Dirt Tooth**  
P/N 34380



## 38mm Teeth



**38mm Dragon's Tooth®**  
P/N 30188



**BKH113 30mm Carbide  
(80mm Gauge)**  
P/N 30225



# 38mm Teeth

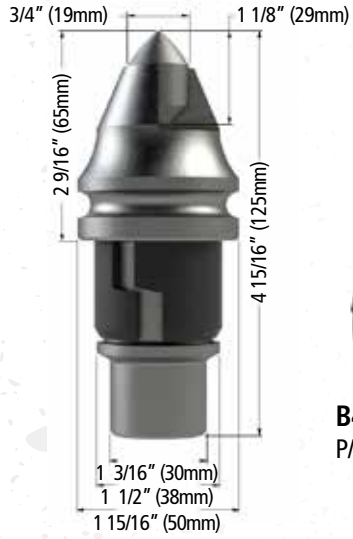

**B47K19H**  
P/N 30162



**B47K19L**  
P/N 30182



**BFZ 100X70/2  
Tooth**  
P/N 34172



**JMI 113X70**  
P/N 34241

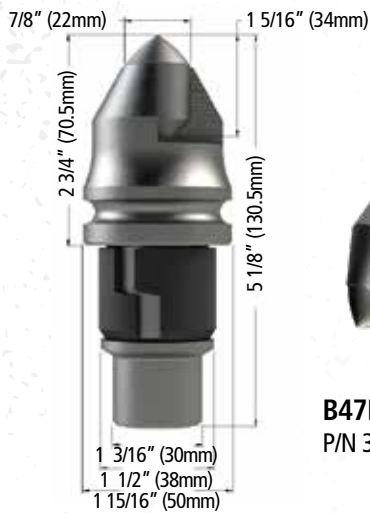

**B47K22-H**  
P/N 30212



**55-1S / C4-1**  
P/N 30242



Hard Surfaced Teeth



**B47K19-L  
Hard Surfaced**  
P/N 30185



**B47K19-H  
Hard Surfaced**  
P/N 30164



**BKH113 30mm  
Carbide  
Hard Surfaced**  
P/N 30226



**.990HB Conical Tooth  
Hard Surfaced**  
P/N 30126



# HOLDERS

## .990 Holders

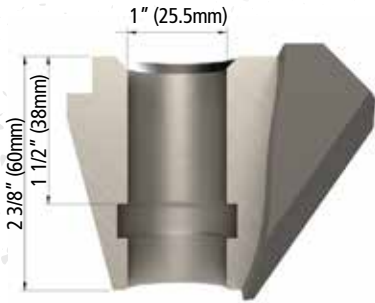

**.990 Dragon's Tooth® Holder**  
P/N 32049

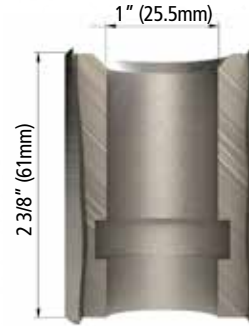

**.990 Machined Holder**  
P/N 32045



**.990 JeffCut® Holder**  
P/N 32150

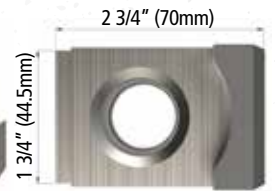
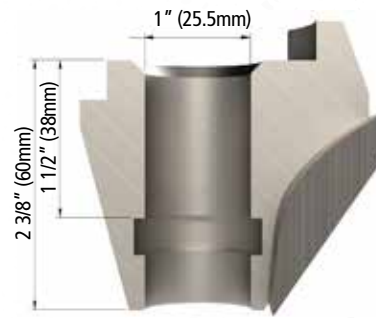

**.990 Tri-Holder**  
P/N 32042

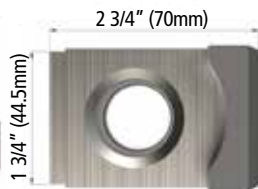
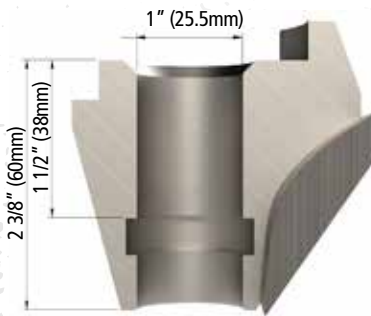

**.990 Jeff444 Tri-Holder**  
P/N 32104

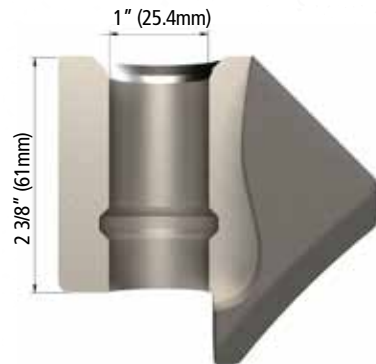

**C-30 .990 Holder**  
P/N 32040



## 38mm Holders

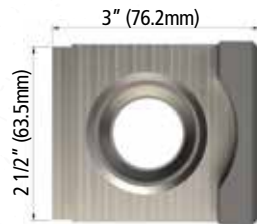
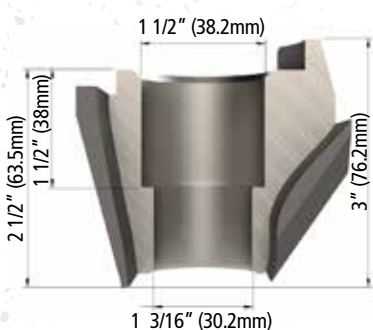

**38mm Jeff444 Tri-Holder**  
P/N 32102

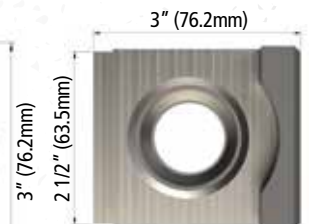
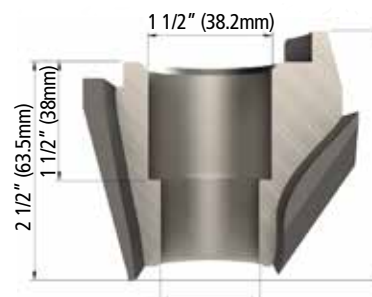

**38mm Tri-Holder**  
P/N 32064



## 38mm Holders

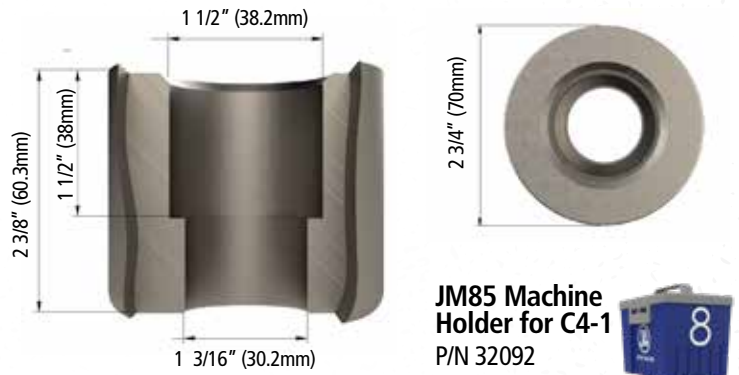
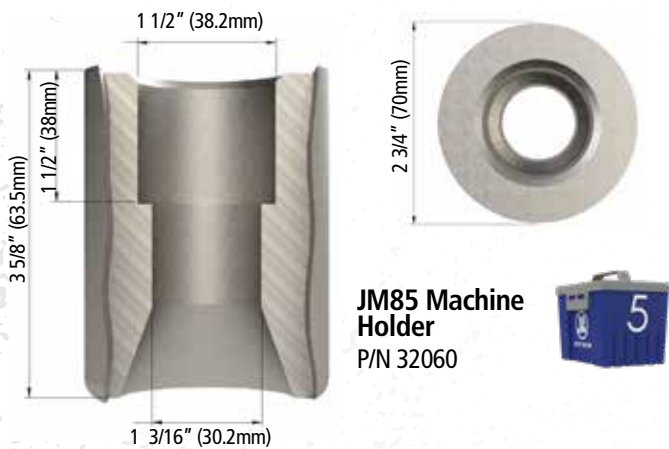
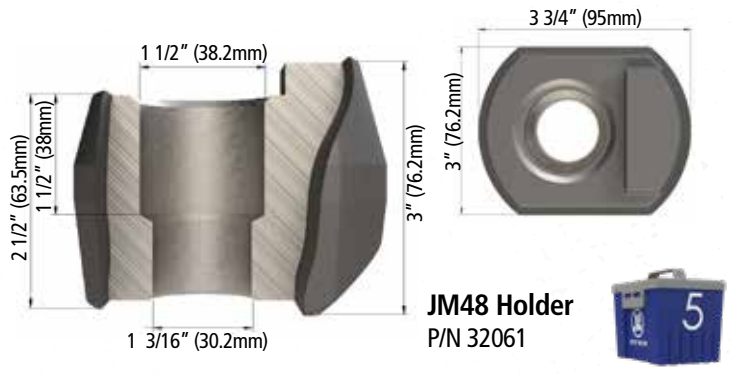
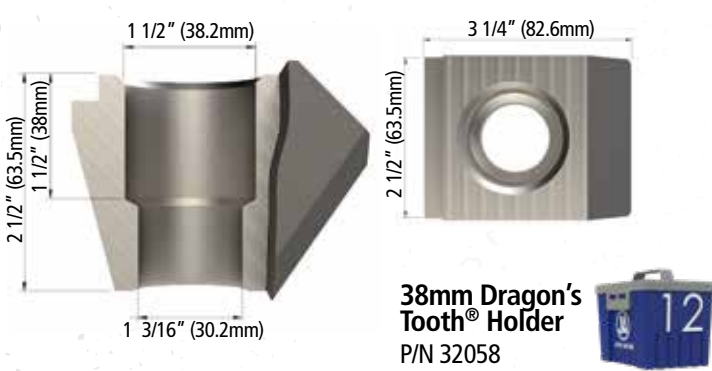

# DIRT TEETH & HOLDERS

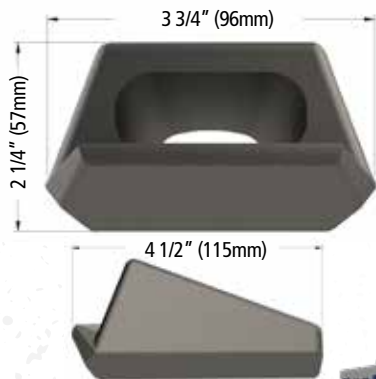

**W0-5 Holder**  
P/N 36010

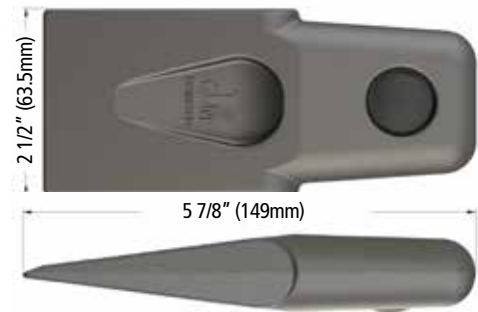

**#201 Dirt Tooth**  
P/N 34100

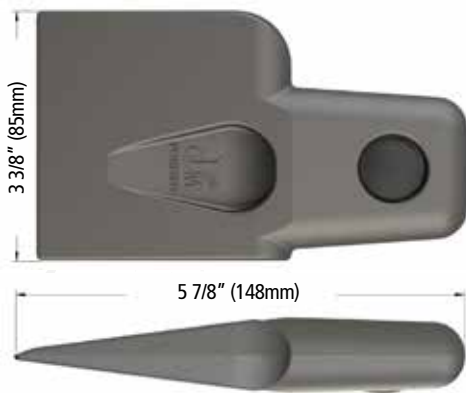

**#211 Dirt Tooth**  
P/N 34110

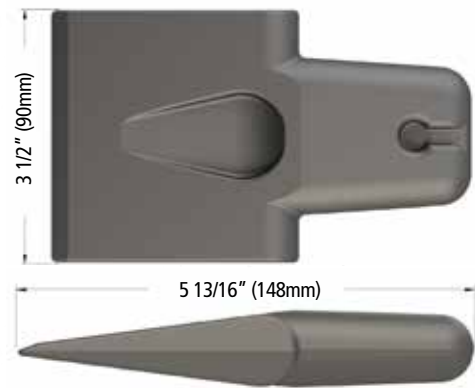

**#132 Dirt Tooth**  
P/N 34251

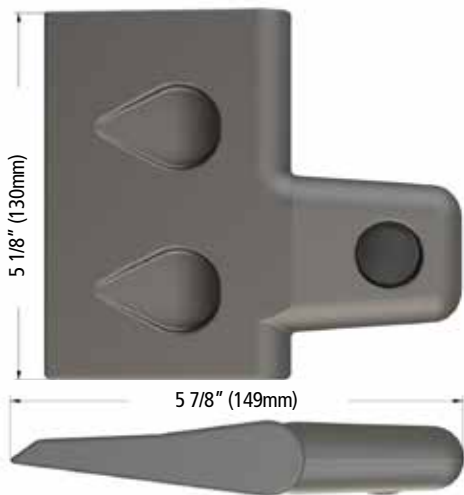

**#134 Dirt Tooth**  
P/N 34255



**#299 Dirt Tooth**  
P/N 34131



**TC-212 Tooth**  
P/N 34274





**W0-1 Holder**  
P/N 36000



**#101 Dirt Tooth**  
P/N 34070



**#111 Dirt Tooth**  
P/N 34080



# PILOT BITS

2 1/2" (63.5mm)



7 1/4" (184mm)  
CUT DIAMETER



**2 1/2" SQ .990 Dragon's Tooth® Pilot**  
P/N 40216

2 3/8" (60.3mm)  
REGULAR API



7 1/4" (184mm)  
CUT DIAMETER



**2 3/8" Reg API .990 Pilot**  
P/N 40410

3 1/2" (88.9mm)  
REGULAR API



7 1/4" (184mm)  
CUT DIAMETER



**3 1/2" Reg API .990 Pilot**  
P/N 40460

2 7/8" (73mm)  
REGULAR API



7 1/4" (184mm)  
CUT DIAMETER



**2 7/8" IF .990 Pilot**  
P/N 40500

3 1/2" (88.9mm)



7 1/4" (184mm)  
CUT DIAMETER



**3 1/2" IF .990 Pilot**  
P/N 40520

2 1/2" (63.5mm)



5 3/4" (146mm)  
CUT DIAMETER

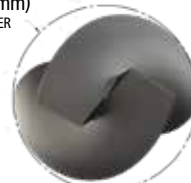

**2 1/2" SQ DB-6 Pilot**  
P/N 40220

2 1/2" (63.5mm)



8" (203mm)  
CUT DIAMETER



**2 1/2" SQ BP-08 Pilot**  
P/N 40470

2 9/16" (65mm)



6" (152.5mm)

**2 1/2" SQ Pilot Adapter**  
P/N 42040



8" (203mm)  
CUT DIAMETER

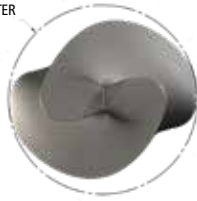

**4" SQ. JM 8" Dirt Pilot**  
P/N 40260

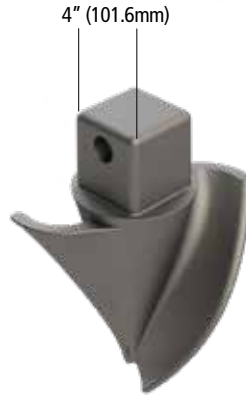

12" (305mm)  
CUT DIAMETER



**4" SQ. JM 12" Dirt Pilot**  
P/N 40264

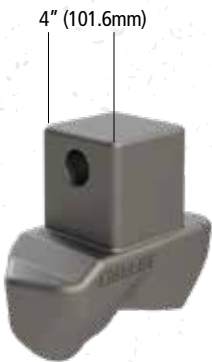

4" (101.6mm)

10 1/4" (260.5mm)  
CUT DIAMETER



**RP-4 Cast Pilot**  
P/N 40280



4" (101.6mm)

11 3/4" (298.5mm)  
CUT DIAMETER



**RP-4 Machined Pilot**  
P/N 40287

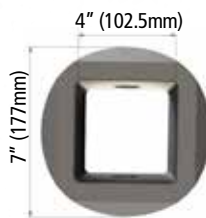

**177mm SQ. Pilot Adapter**  
P/N 42080

# MISCELLANEOUS PARTS



**CJ2 Holder**  
P/N 36070



**CJ2 Tooth**  
P/N 34220



**2" x 3" x 1/2" Wear Pads**  
P/N 39302



**2" x 3" x 5/8" Wear Pads**  
P/N 39304



**1 1/2" X 3" X 1/2" Wear Pads**  
P/N 39303



**3/4" Hex Weld Bars**  
P/N 34350



**1 1/8" Hex Weld Bars**  
P/N 34340



**1 3/8" Hex Weld Bars**  
P/N 34330



**Soft Hammer**  
P/N 39150



**Knock Out Punch**  
P/N 30562  
*Recommended for Dragon's Teeth®*

## BULLET TOOTH PULLERS



**123 Bullet Tooth Puller**  
P/N 30542

**.990 Bullet Tooth Puller**  
P/N 30512

**38mm Series Puller**  
P/N 30524



**Jeffrey Combination  
Knock Out & Tooth Insertion Tool**  
P/N 30570



# JEFFREY MACHINE WARRANTY DISCLAIMER

Products manufactured by Jeffrey Machine are subject to wear; and occasional breakage should, therefore, be expected.

Jeffrey Machine products are warranted from defects in material and workmanship for a period of 30 days from the date of invoice.

Jeffrey Machine reserves the right to inspect all failure that may occur before any repairs or modifications from original manufacturing design are performed.

Any repairs or modifications performed without written permission from Jeffrey Machine will void all warranty.

In no event shall Jeffrey Machine be liable for consequential or incidental damages.

WARRANTY DISCLAIMER



# DERRICK AUGER FEATURES & BENEFITS

It's important to note that we manufacture all of our own tools so we can tightly control the quality.

We can also customize as needed.

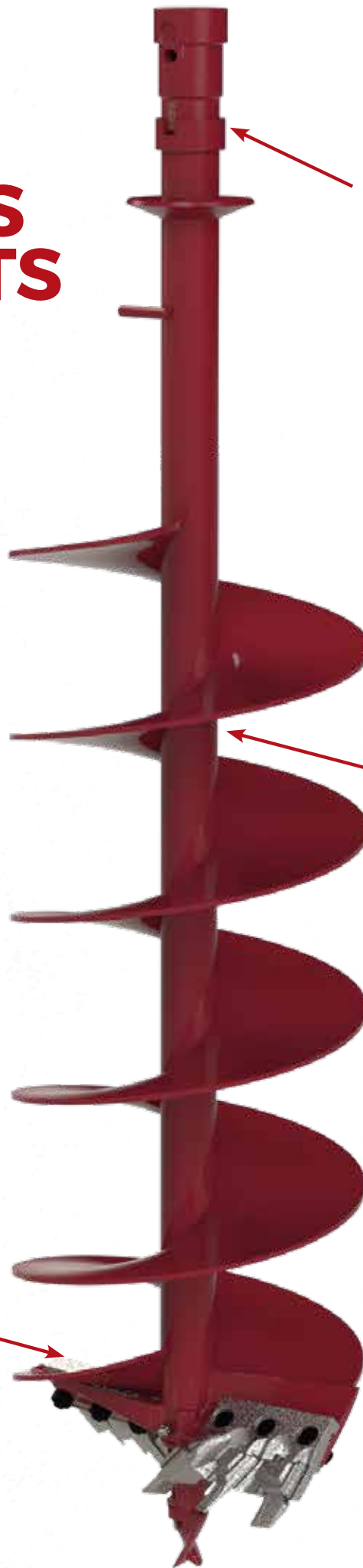

Derrick augers come equipped with heavy duty hex collars

D.O.M. Hydraulic Tube  
85,000 P.S.I.

Gusset (**extra *flighting start***) for better balanced cut and added strength means **less wear and tear on your rig.**

Augers come equipped with 1" thick lower flighting

# HOW TO ORDER

## SELECT YOUR MODIFICATIONS

Mix and match shanks, bits and pilots for a large number of possibilities that can be made to specifically fit your application.

### HEX COUPLERS, HUBS & ADAPTERS

Available in multiple sizes, SEE PAGE 94.

### AUGER LENGTH

Overall length of 104".

### FLIGHTING

40" to 60" of 3/8" flighting available. SEE PAGE 121.

### MEDIUM DUTY CENTER HEADS

Available from 8" to 48", SEE PAGE 95.

### SHANK PLATES

Available in multiple teeth type and quantities, SEE PAGES 96-97.

### TEETH

For a list of available teeth for Derrick Augers, SEE PAGE 99.

### PILOT ADAPTERS

For a pilot adapter available, SEE PAGE 105.

### PILOT BITS

For a list of all available, SEE PAGES 104-105.

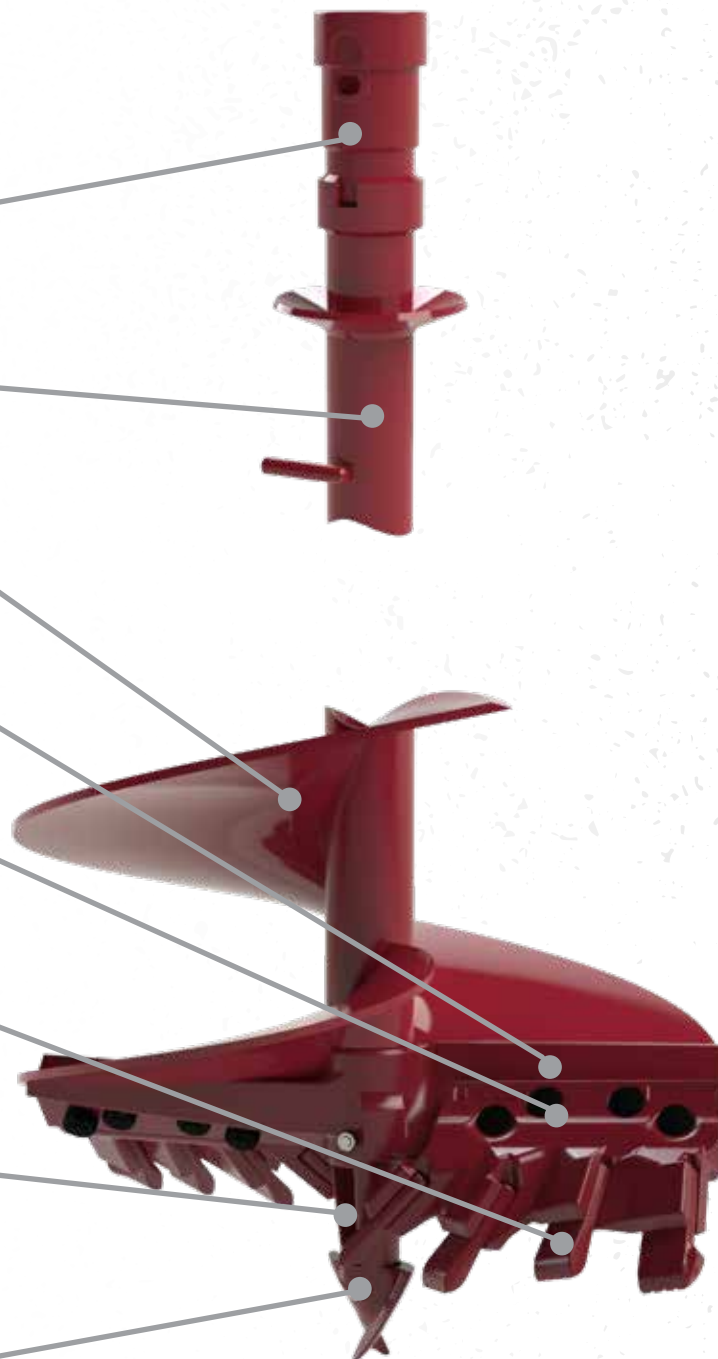

Custom orders cannot be refunded, canceled, or returned for any reason.

## EXPLODED VIEW

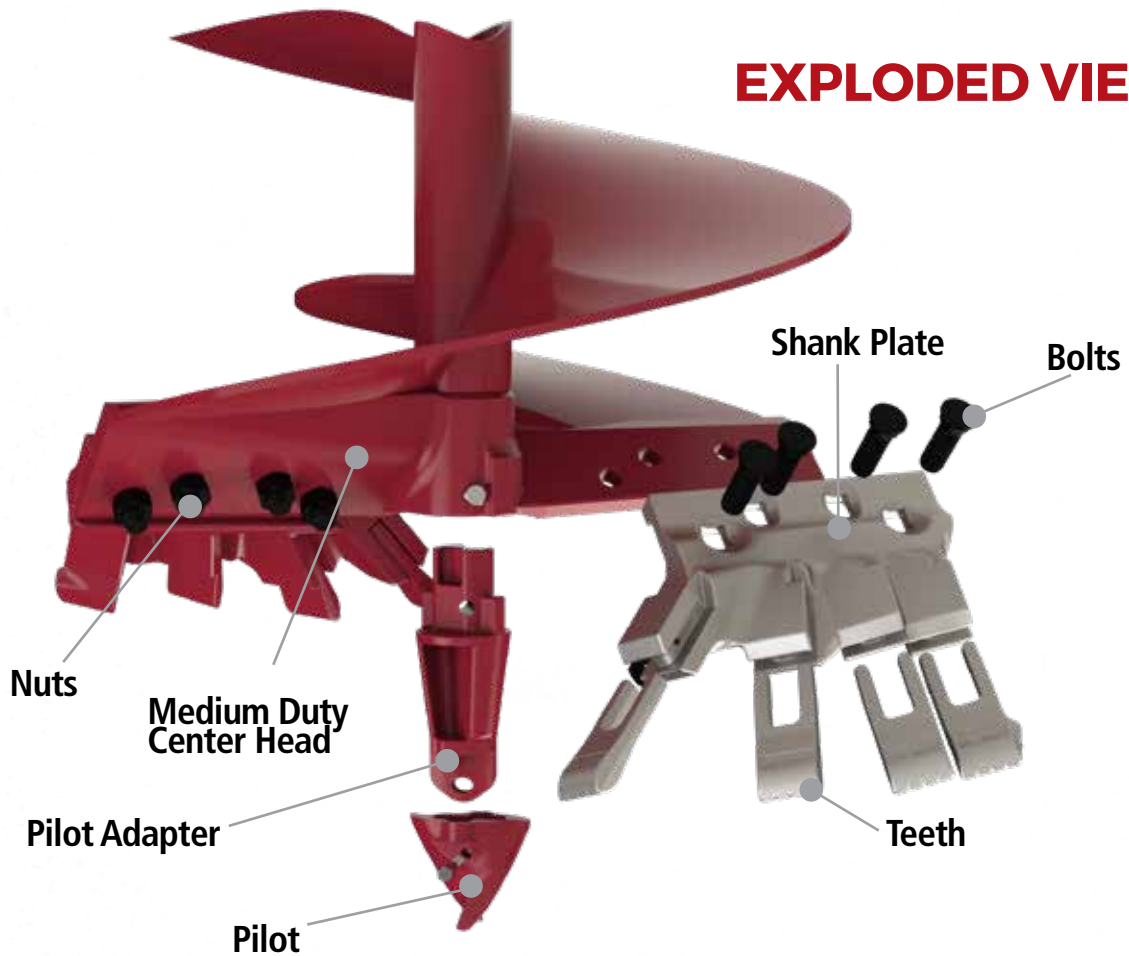

## 4 BASIC SET-UPS

### MEDIUM DUTY DIRT

Loose and compacted soils, stiff clays and soft shelves. (SHOWN ABOVE)

### MEDIUM DUTY BOLT-ON BULLET

Limestone, lava rock, medium sand stone and frozen materials. Medium to hard formations. (SEE PAGE 90)

### MEDIUM DUTY CARBIDE

High abrasion, frozen soil, low impact. (SHOWN ABOVE)

### MEDIUM DUTY BOLT-ON DRAGON'S TOOTH®

Aggressively cuts through limestone, coral, lava rock, medium sand stone and frozen materials. Medium to hard formations. (SEE PAGE 91)

# UTILITY DIRT TOOTH AUGER

The right tool for loose and compacted soils, stiff clays, and soft shales.



## UTILITY DIRT AUGER WITH FH-205 DIRT PILOT

- 2", 2 1/2", and 2 5/8" hex hubs.
- Overall length of 104", with 40" to 60" of 3/8" thick flighting.



**1652 Gauge  
Dirt Tooth**  
P/N 34010



**FH-205 Dirt Pilot**  
P/N 40000



**1650 Dirt  
Tooth**  
P/N 34000

Diameter	Part No.
9"	9-104-60DA
10"	10-104-60DA
12"	12-104-60DA
14"	14-104-60DA
16"	16-104-60DA
18"	18-104-60DA
20"	20-104-60DA
22"	22-104-60DA
24"	24-104-60DA
30"	30-104-48DA
36"	36-104-48DA
42"	42-104-48DA
48"	48-104-48DA

# MEDIUM DUTY BOLT-ON CARBIDE AUGER

The right tool for high abrasion, frozen soil, and low impact.



## MEDIUM DUTY BOLT-ON CARBIDE AUGER WITH FH-205HFTC CARBIDE PILOT PILOT

- 2", 2 1/2", and 2 5/8" hex hubs.
- Overall length of 104", with 40" to 60" of 3/8" thick flighting.



**1656 Carbide  
Tooth**  
P/N 34030



**FH-205HFTC**  
P/N 40010



**1658 Carbide  
Tooth**  
P/N 34040

Diameter	Part No.
9"	9-104-60CA
10"	10-104-60CA
12"	12-104-60CA
14"	14-104-60CA
16"	16-104-60CA
18"	18-104-60CA
20"	20-104-60CA
22"	22-104-60CA
24"	24-104-60CA
30"	30-104-48CA
36"	36-104-48CA
42"	42-104-48CA
48"	48-104-48CA

# MEDIUM DUTY BULLET TOOTH AUGER

The right tool for solid rock, fracturable rock, and compacted soils.



**2 3/8" Reg API  
.765 Pilot**  
P/N 40100



**1 3/4" Square  
Pilot**  
P/N 40180



**.765CB  
Conical Tooth**  
P/N 30042

## MEDIUM DUTY BULLET TOOTH AUGER WITH 1 3/4" SQUARE ROCK PILOT OR API ROCK PILOT

- 2", 2 1/2", and 2 5/8" hex hubs.
- Overall length of 104", with 40" to 60" of flighting.
- 1" thick lower flight, 3/8" upper flight, and standard pilot bit.

Diameter	Part No.
9"	9-104-60BA
10"	10-104-60BA
12"	12-104-60BA
14"	14-104-60BA
16"	16-104-60BA
18"	18-104-60BA
20"	20-104-60BA
22"	22-104-60BA
24"	24-104-60BA
30"	30-104-48BA
36"	36-104-48BA
42"	42-104-48BA
48"	48-104-48BA

# MEDIUM DUTY DRAGON'S TOOTH® AUGER

The right tool for solid rock, fracturable rock, and compacted soils.

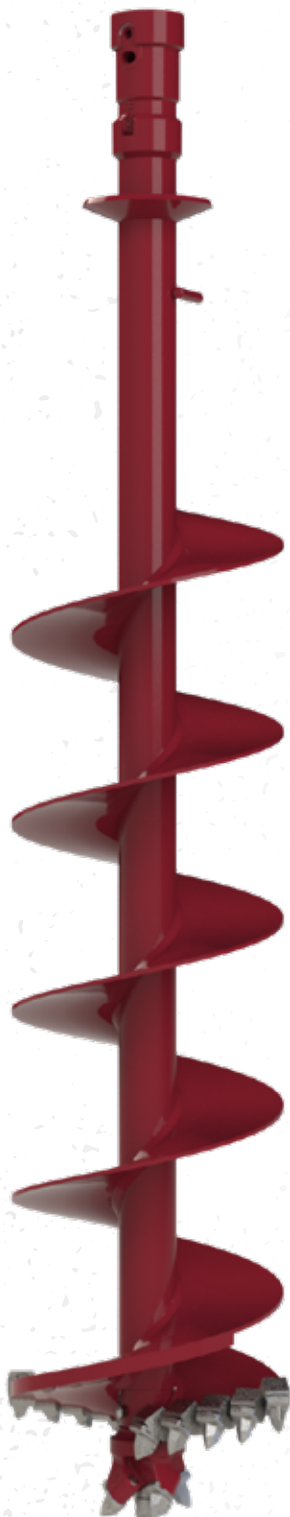

## MEDIUM DUTY DRAGON'S TOOTH® AUGER WITH 1 3/4" SQUARE ROCK PILOT

- 2", 2 1/2", and 2 5/8" hex hubs.
- Overall length of 104", with 40" to 60" of 3/8" thick flighting.
- 1" thick lower flight, 3/8" upper flight, and standard pilot bit.



**1 3/4" Square  
Dragon's Tooth®  
.875 Pilot**  
P/N 40239



**.875 Dragon's  
Tooth®**  
P/N 30112

Diameter	Part No.
9"	9-104-60DRA
10"	10-104-60DRA
12"	12-104-60DRA
14"	14-104-60DRA
16"	16-104-60DRA
18"	18-104-60DRA
20"	20-104-60DRA
22"	22-104-60DRA
24"	24-104-60DRA
30"	30-104-48DRA
36"	36-104-48DRA
42"	42-104-48DRA
48"	48-104-48DRA

\* The Dragon's Tooth® is an original design of Jeffrey Machine, Inc.

# MEDIUM DUTY BOLT-ON BULLET TOOTH AUGER

The right tool for limestone, lava rock, medium sand stone, and frozen materials.  
Best used in medium to hard formations.



## UTILITY BOLT-ON BULLET AUGER WITH RCP-6.5 ROCK PILOT

- 2", 2 1/2", and 2 5/8" hex hubs.
- Overall length of 104", with 40" to 60" of 3/8" thick flighting.
- RCP-6.5 Rock Pilot

Diameter	Part No.
16"	16-104-60BOB
18"	18-104-60BOB
20"	20-104-60BOB
24"	24-104-60BOB



**RCP-6.5 Pilot**  
P/N 40240



**.875 Bullet Tooth**  
P/N 30082



**Rock Shank Plate**  
Reference page 96  
for available sizes

# MEDIUM DUTY BOLT-ON DRAGON'S TOOTH® AUGER

Consumes limestone, lava rock, coral, medium sand stone, and frozen materials.  
Excels in medium to hard formations.

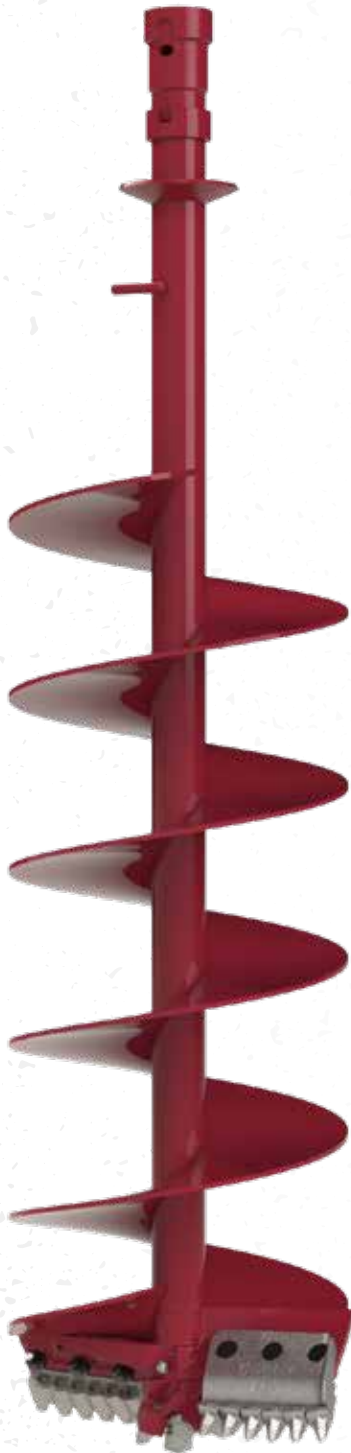

## UTILITY BOLT-ON DRAGON'S TOOTH® WITH DCP-6.5 ROCK PILOT

- 2", 2 1/2", and 2 5/8" hex hubs.
- Overall length of 104", with 40" to 60" of 3/8" thick flighting.

Diameter	Part No.
16"	16-104-60BOD
18"	18-104-60BOD
20"	20-104-60BOD
24"	24-104-60BOD



**DCP-6.5  
Pilot**  
P/N 40238



**Dragon's Tooth®  
Shank Plate**  
Reference page 96  
for available sizes



**.875 Dragon's  
Tooth®**  
P/N 30112

*\*The Dragon's Tooth® is an original design of Jeffrey Machine, Inc.*

# SPIRAL DRAGON'S TOOTH® ROCK AUGER

The right tool for solid rock, fracturable rock, and compacted soils.



## SPIRAL DRAGON'S TOOTH® ROCK AUGER

- 2", 2 1/2", and 2 5/8" hex hubs.
- Overall length of 104", with 40" to 60" of 3/8" thick flighting.
- 1" thick lower flight, 3/8" upper flight, and standard pilot bit.



**1 3/4" Square  
Dragon's Tooth®  
.875 Pilot**  
P/N 40239



**.875 Dragon's  
Tooth®**  
P/N 30112

Diameter	Part No.
9"	9-104-60SDA
10"	10-104-60SDA
12"	12-104-60SDA
14"	14-104-60SDA
16"	16-104-60SDA
18"	18-104-60SDA
20"	20-104-60SDA
22"	22-104-60SDA
24"	24-104-60SDA
30"	30-104-48SDA
36"	36-104-48SDA
42"	42-104-48SDA
48"	48-104-48SDA



# HEX COUPLERS, HUBS & ADAPTERS

## HEX ADAPTERS



2.5" Hex Hub X  
2" Hex Male  
P/N 28000



2.5" Hex Hub X  
2.625" Hex Male  
P/N 28002



2" Hex Hub X  
2.5" Hex Male  
P/N 28003



2.625" Hex Hub X  
2.5" Hex Male  
P/N 28004

## HEX COUPLERS



2" Hex X 2"  
Hex Coupler  
P/N 27000F



2.5" Hex X 2"  
Hex Coupler  
P/N 27010



2.625" Hex X 2.625"  
Hex Coupler  
P/N 27020F



2.625" Hex X 2" Hex  
Coupler  
P/N 27030



2.625" Hex X 2.5"  
Hex Coupler  
P/N 27040



2.5" Hex X 2.5" Hex  
Coupler  
P/N 27050

## HEX HUBS



2" Hex Hub  
P/N 43030



2 1/2" Hex Hub  
P/N 43050



2 5/8" Hex Hub  
P/N 43070



3" Hex Hub  
P/N 43080

# MEDIUM DUTY CENTER HEADS

Description	Part Number
8" MD Center Head	38000
9" MD Center Head	38010
10" MD Center Head	38020
12" MD Center Head	38030
14" MD Center Head	38040
16" MD Center Head	38050
18" MD Center Head	38060
20" MD Center Head	38070
22" MD Center Head	38080
24" MD Center Head	38090
30" MD Center Head	38100
36" MD Center Head	38110
42" MD Center Head	38120
48" MD Center Head	38130



**8" MD Center Head**  
P/N 38000



**12" MD Center Head**  
P/N 38030



**18" MD Center Head**  
P/N 38060



**24" MD Center Head**  
P/N 38090



**30" MD Center Head**  
P/N 38100



**48" MD Center Head**  
P/N 38130

# SHANK PLATES

Description	Part Number	Teeth Quantity
810x	37000	1
12x	37020	2
145x	37040	2
16 x 1	37050	2
16 x 2	37060	2
18 x 1	37070	3
18 x 2	37080	3
20 x 1	37090	3
20 x 2	37100	3
22 x 1	37110	3
22 x 2	37120	3
24 x 1	37130	3
24 x 2	37140	4
267 x 1	37150	4
267 x 2	37160	4
30 x 1	37170	4
30 x 2	37180	4
36 x 1	37190	4
36 x 2	37200	4
42 x 1	37210	5
42 x 2	37220	5
48 x 1*	37230	2
48 x 2*	37240	3



**810x**  
Teeth Quantity: 1  
P/N 37000



**16 x 1**  
Teeth Quantity: 2  
P/N 37050



**18 x 2**  
Teeth Quantity: 3  
P/N 37080



**267 x 1**  
Teeth Quantity: 4  
P/N 37150



**42 x 1**  
Teeth Quantity: 5  
P/N 37210



**48 x 2**  
Teeth Quantity: 3  
P/N 37240

\*Only outside shank. Must be used with a 36 x 1 or 36 x 2 shank sold separately.



**C016 Blank**  
P/N 37310



**C018 Blank**  
P/N 37320



**C020 Blank**  
P/N 37330



**C024 Blank**  
P/N 37340

# ROCK SHANK KITS

Includes shank plates for bullet teeth and Dragon's Teeth®, the teeth and pilots.

## ROCK SHANK KIT



Description	Quantity of Teeth per Shank
RSK16 Shank Plate Kit & Pilot (37900)	4
RSK18 Shank Plate Kit & Pilot (37910)	5
RSK20 Shank Plate Kit & Pilot (37920)	5
RSK24 Shank Plate Kit & Pilot (37930)	6

## DRAGON'S TOOTH® SHANK KIT



Description	Quantity of Teeth per Shank
DSK16 Dragon's Tooth® Shank Plate Kit (37940)	4
DSK18 Dragon's Tooth® Shank Plate Kit (37950)	5
DSK20 Dragon's Tooth® Shank Plate Kit (37960)	5
DSK24 Dragon's Tooth® Shank Plate Kit (37970)	6

# TWIN HELIX AUGER

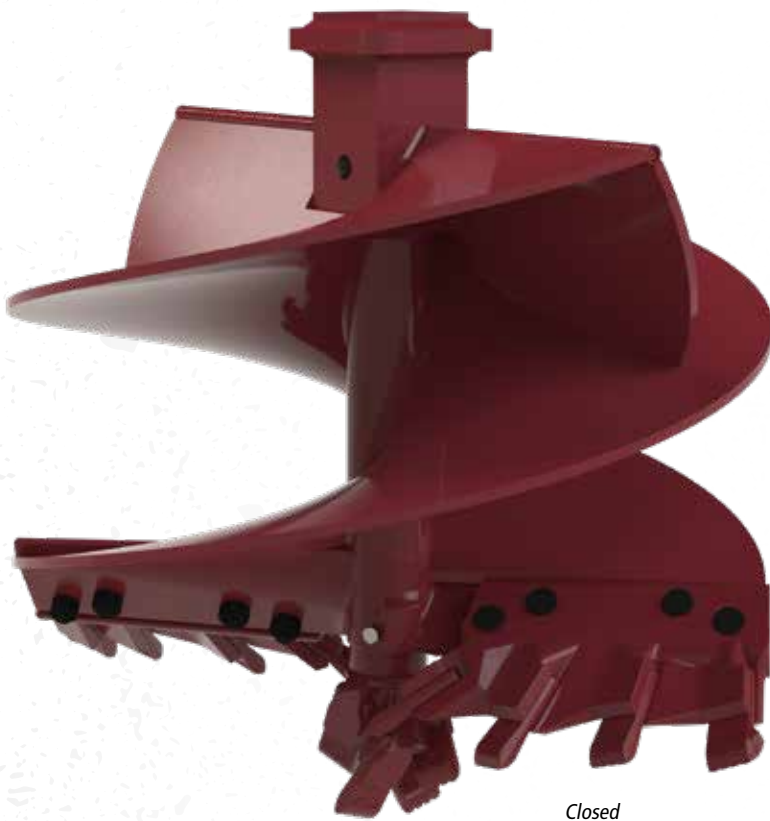

Closed



Open

## TWIN HELIX AUGER SPECIFICATIONS

**Commonly Requested Diameters:** 18" – 36"

**Type:** Medium Duty Boring Head (type-6)

**Cut:** DC/DF or DC/SF

**Kelly boxes:** All kelly boxes made to customer specifications

**Center Shaft:** 4" Solid Shaft

**Flight:** 3/8" - 1" thickness available



**1650 Dirt Tooth**  
P/N 34000



**1652 Gauge Tooth**  
P/N 34010



**1656 Carbide Tooth**  
P/N 34030



**1658 Carbide Tooth**  
P/N 34040



## CONSOLIDATED ROCK / ABRASIVE SOIL PILOT

Carbide - 1656 / 1658 teeth

P/N 40050 (P1656)

Dirt - 1650 / 1652 teeth

P/N 40040 (P1650)

# TEETH & HOLDERS

## 16 Series

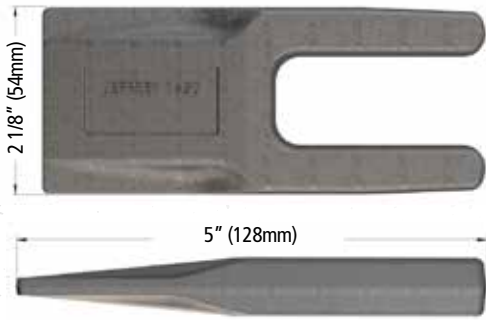

**Standard Digging  
1650 Dirt Tooth**  
P/N 34000



**Standard Digging  
1652 Gauge Tooth**  
P/N 34010



**Tungsten Carbide  
Tooth 1656**  

- Highly abrasive soil
- Low impact

P/N 34030



**Carbide Gauge  
Tooth 1658**  

- Highly abrasive soil

P/N 34040

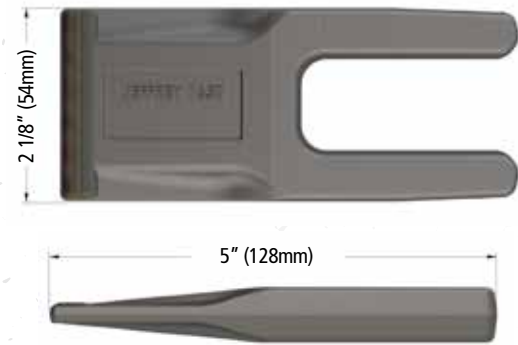

**1650 HFFTC Tooth**  

- Abrasive soil
- Impact, hard faced with carbide chips on two sides

P/N 34002



**1ft. Length Rubber Lok**  
P/N 39110

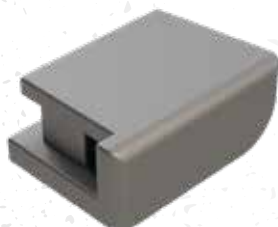

**1 X S Holder**  
P/N 36040



**WT50 Holder**  
P/N 36050



# TEETH & HOLDERS

## 20 Series



**2077 Carbide Tooth**  
P/N 34050



**2078 Carbide Tooth**  
P/N 34060

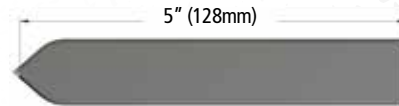

**WA-70**  
P/N 36030



# TEETH & HOLDERS

## CARBIDE FACED TOOTH

- Carbide faced tooth for the step rock auger
- Best used in solid, non-fracturable rock



**PFC-5**  
P/N 34200



**PFC-5H**  
P/N 36020



**TWT-2**  
P/N 34210



**TDB31 Tooth**  
P/N 34140

## 101 & 111 TOOTH HOLDER



**W0-2 Holder**  
P/N 36060



**BFZ 222 Tooth**  
P/N 34192



**CB10 Tooth**  
P/N 34230

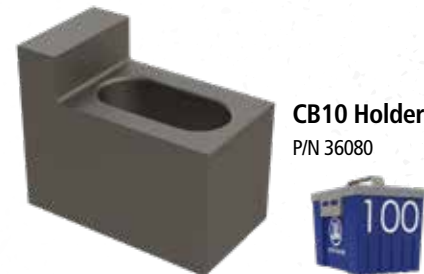

**CB10 Holder**  
P/N 36080

# ACCESSORIES



39110	1 ft. Length Rubber Lock
39150	Soft Hammer

## BULLET TOOTH PULLERS

**123 Bullet Tooth Puller**  
Fits .735, .765 and .875 Teeth  
P/N 30542



**Knock Out Punch**  
P/N 30562



# TEETH & HOLDERS

11/16" (16mm) 1/2" (13.3mm)



**.735CB Conical Tooth**  
P/N 30012



7/16" (12mm) 3/4" (19mm)



**.735HB Conical Tooth**  
P/N 30022



5/8" (16mm) 1/2" (13.3mm)



**.765CB Conical Tooth**  
P/N 30042



1/2" (12mm) 3/4" (19mm)



**.765HB Conical Tooth**  
P/N 30062



1/2" (12mm) 3/4" (19mm)



**.765HS Conical Tooth**  
P/N 30072



5/8" (16mm) 1/2" (13.3mm)



**.875CS Conical Tooth**  
P/N 30082



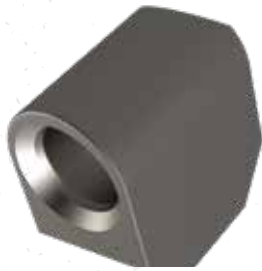

**.735 Holder**  
P/N 32011

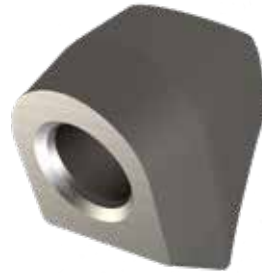

**.765 Holder**  
P/N 32021

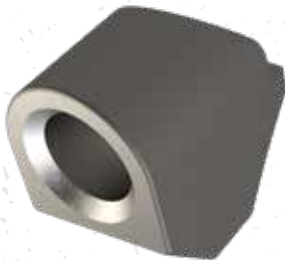

**.875 Holder**  
P/N 32035



**.875 JeffCut® Holder**  
P/N 32004



### **DRAGON'S TOOTH® NON-ROTATING TOOTH**

- Fits .875 Dragon's Tooth® holder
- Non-rotating design
- Large long-life carbide
- Shank plates and pilots available

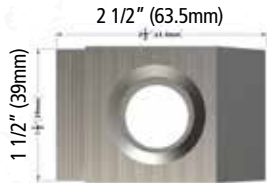

**.875 Machined  
Dragon's Tooth®  
Holder**  
P/N 32000



**.875 Dragon's  
Tooth®**  
P/N 30112-N



# PILOT BITS & ADAPTERS



## RCP 6.5 BOLT-ON AUGER PILOT

6 1/2" Cut Diameter

.875 Bullet Teeth and CP-18 Carbide Pilot Tip

P/N 40240



## CP-18 PILOT

1 1/8" - 4 UNC

P/N 40390



## STANDARD DIRT PILOT - FH205

Best utilized in standard dirt applications

P/N 40000



## 4 3/4" CARBIDE PILOT (2 3/8" API THREAD)

Best used in solid, non-fracturable rock

P/N 40080 (P6000)



## CONSOLIDATED ROCK / ABRASIVE SOIL PILOT

Carbide - 1656 / 1658 teeth

P/N 40050 (P1656)

Dirt - 1650 / 1652 teeth

P/N 40040 (P1650)



## 1 3/4" SQUARE .765 ROCK PILOT

Works well on fractured to non-fractured rock. Also available with 2 3/8" API thread.

P/N 40180



## CONSOLIDATED ROCK / ABRASIVE SOIL PILOT

- Hard faced both sides

- Impact possible

P/N 40010 (FH205-HFTC)



## 5" CARBIDE TIPPED DRILL HEAD 5.0-TCH-171

5" diameter carbide tipped drill head is best used in concrete, stone, and frozen ground

P/N 40060



## PILOT ADAPTER PA-183-L

Comes with a bolt and nut

P/N 42010



**2 3/8" Reg API Pilot  
.875 Dragon's Tooth®**  
P/N 40131



**2 3/8" Reg API .875  
Pilot**  
P/N 40122



**.875 Dragon's Tooth® Pilot  
Standard Blank**  
P/N 40234



**(TPB-2) 1-3/4" SQ .765  
Pilot Blank (Short)**  
P/N 40170S



**.875 1 3/4" Square  
Dragon's Tooth® Pilot Blank**  
P/N 40235



**1 3/4" Cast MM1 Pilot**  
P/N 40192



**FH-105 Pilot**  
P/N 40020



**1-3/4" SQ. DB-175 Adapter**  
P/N 42020



**1-3/4" SQ. DB-175-A  
Adapter**  
P/N 42030



**3 1/2" Reg API  
Male Pin**  
P/N 40430



**3 1/2" Reg API Pilot FM  
Adapter**  
P/N 42090



**2 3/8" API Pilot  
FM Adapter**  
P/N 42050



**2 3/8" Reg API  
Male Pin**  
P/N 40420



**2 7/8" Reg API Pilot  
FM Adapter**  
P/N 42060



**2 7/8" IF FM Pilot  
FM Adapter**  
P/N 42070

# KELLY BARS

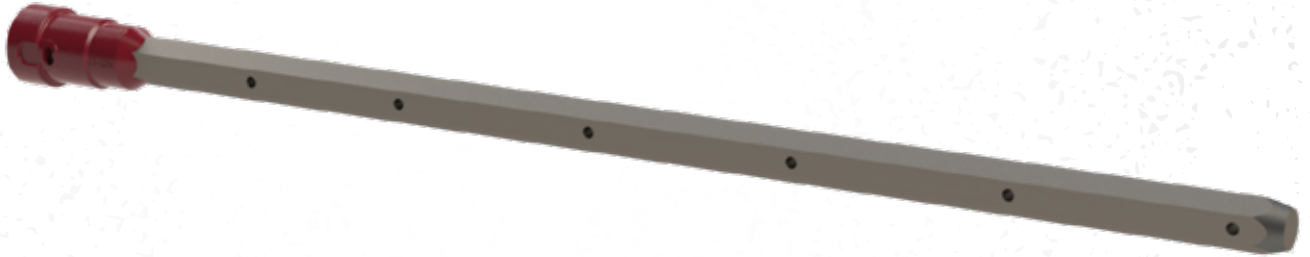

## KELLY BAR HEX EXTENSION SHAFTS WITH HUB & HOLES

Part No.	Hub Size	Bar Size	Bar Length
25025	2"	2"	72"
25075	2 1/2"	2 1/2"	72"
25130	2 5/8"	2 5/8"	72"
25140	3"	3"	72"



## KELLY BAR HEX EXTENSION SHAFTS WITH HOLES

Part No.	Bar Size	Bar Length
25005	2"	72"
25055	2 1/2"	72"
25095	2 5/8"	72"
25145	3"	72"

\*Custom lengths and combinations of hubs and kelly bars available

# DERRICK CORE BARREL

## DERRICK CORE BARREL SPECIFICATIONS

**Common Diameters:** 16", 18", 20", 24" (Other sizes available upon request.)

**Hex Hubs:** 2", 2 1/2", 2 5/8" and 3"

**Extensions:** Standard length approx. 83". Hex connecting pin and hardware included. (Length can be specified by customer.)

**Barrels:** 1" wall. Solid, single or double window available.

**Barrel Height:** Standard height is 36". (Height can be specified by customer.)



**.735CB Conical Tooth**  
P/N 30012



**.765CB Conical Tooth**  
P/N 30042



**.875CS Conical Tooth**  
P/N 30082



**.875 Dragon's Tooth®**  
P/N 30112-N

\* .990 Conical and .990 Dragon's Tooth® available for Derrick Core Barrels using 3" Hex.



**.735 Holder**  
P/N 32011



**.765 Holder**  
P/N 32021



**.875 JeffCut® Holder**  
P/N 32004

# LIGHT DUTY AUGERS

Available in sizes 6" to 48"

## LIGHT DUTY ROCK AUGER

WITH 1 3/4" SQUARE ROCK PILOT WITH .765 TEETH

- 2", 2 1/2", 2 5/8" hex hubs
- 2", 2 9/16" round hubs
- Overall length of 42" - 48"
- 1" thick lower flight, 3/8" upper flight



18" LD Boring Head  
P/N 47070



24" LD Boring Head  
P/N 47090



36" LD Boring Head  
P/N 47110



42" LD Boring Head  
P/N 47120



48" LD Boring Head  
P/N 47130



Diameter	Part No.
6"	9706LDRA
8"	9708LDRA
9"	9709LDRA
10"	9710LDRA
12"	9712LDRA
14"	9714LDRA
16"	9716LDRA
18"	9718LDRA
20"	9720LDRA
22"	9722LDRA
24"	9724LDRA
30"	9730LDRA
36"	9736LDRA
42"	9742LDRA
48"	9748LDRA

## LIGHT DUTY DIRT/CARBIDE AUGER

WITH 35 SERIES DIRT OR CARBIDE TEETH

- 2", 2 1/2", 2 5/8" hex hubs
- 2", 2 9/16" round hubs
- Overall length of 42" - 48"
- 3/8" thick flighting



Diameter	Dirt P/N	Carbide P/N
6"	9706LDDA	9706LDCA
8"	9708LDDA	9708LDCA
9"	9709LDDA	9709LDCA
10"	9710LDDA	9710LDCA
12"	9712LDDA	9712LDCA
15"	9715LDDA	9715LDCA
16"	9716LDDA	9716LDCA
18"	9718LDDA	9718LDCA
20"	9720LDDA	9720LDCA
24"	9724LDDA	9724LDCA
30"	9730LDDA	9730LDCA
36"	9736LDDA	9736LDCA
42"	9742LDDA	9742LDCA
48"	9748LDDA	9748LDCA

# LIGHT DUTY TEETH, PILOTS & ACCESSORIES

## 13 Series



**1335 Dirt Tooth**  
Application: Ordinary digging  
P/N 45000



**1335-HFF Carbide Hard Faced Tooth**  
Application: Abrasive frozen soil  
P/N 45020



**1336 Carbide Insert Tooth**  
Application: Abrasive frozen soil  
P/N 45030



**1337 Gauge Dirt Tooth**  
Application: Ordinary digging  
P/N 45040



**1338 Carbide Gauge Tooth**  
Application: Abrasive frozen soil  
P/N 45110



**5T30 Chisel Point Tooth**  
Application: Loose rock, compacted  
P/N 45070



**5T30-C Chisel Point Tooth with Carbide**  
Application: Compacted rock, abrasive soil - no impact  
P/N 45080



**BC58F Dirt Tooth**  
Application: Ordinary digging  
P/N 45102



**1.250in Dirt Pilot (82-P2-35)**  
P/N 46070



**82-P2-34 LD 1.250in Sq. Pilot Adapter**  
P/N 46090



**2 9/16in Round Hex Hub**  
P/N 43060



**0.625in Plow Bolt and Nut**  
P/N 45125

# LIGHT DUTY AUGER RACK



The light duty auger rack can hold up to eight augers in sizes ranging from a 3" Hex Hub to a 2" Hex Hub. Also, if you need storage space you can have up to six drawers installed for parts and pieces. It is meant to be mobile, so put it in the back of your work truck to have all your tools and pieces ready to go at the jobsite.



**JM**  
**JEFFREY MACHINE**  
Mobile LD

**JM**  
**JEFFREY MACHINE INC.**  
DRIVEN BY PRECISION

# ANCHOR PLACEMENT TOOLS & ACCESSORIES



## 5 1/4" BOLT CIRCLE KELLY BAR ADAPTERS For 10,000 ft. lb. maximum installing torque

Each of these Kelly bar adapters has six holes for 1/2" bolts on a 5 1/4" bolt circle and comes with six 1/2" grade 5 bolts, nuts and lock washers, and bent arm pin with coil lock.



### 2" Kelly Bar Adapter

Shape: **Hex**  
Weight: 10 lb.  
Dimensions:  
X: 2" Y: 5" Z: 6 1/8"  
P/N 20350



### 2 1/2" Kelly Bar Adapter

Shape: **Hex**  
Weight: 10 lb.  
Dimensions:  
X: 2 1/2" Y: 4 1/4" Z: 8 1/4"  
P/N 20040



### 2 5/8" Kelly Bar Adapter

Shape: **Hex**  
Weight: 10 lb.  
Dimensions:  
X: 2 5/8" Y: 4 1/4" Z: 8 1/4"  
P/N 20050

## STANDARD LOCKING DOG ASSEMBLY For 10,000 ft. lb. maximum installing torque



Has six 1/2" holes on 5 1/4" bolt circle, and includes six 1/2" grade 5 bolts, nuts and lock washers.

### Standard Locking Dog

P/N 20090



### 6 Bolt Locking Dog Replacement Kit

P/N 20101

## FOR SS HELICAL PIER ANCHORS

These drive tools require the appropriate Kelly bar adapter. Each comes with bolts, nuts and lock washers, and a bent arm retaining pin with coil lock.



### SS5/SS150 Anchor Series

Bolt Circle: 5 1/4"  
6 Holes: 1/2"  
Approx. Weight: 7 lb.  
P/N 20030

### SS175 Anchor Series

Bolt Circle: 7 5/8"  
12 Holes: 5/8"  
Approx. Weight: 18 lb.  
P/N 20131



### SS5/SS150/RR Drive Tool Fits 6 Bolt Locking Dog

Approx. Weight: 8 lb.  
P/N 20081

### SS5/SS150/RR Drive Tool Fits 12 Bolt Locking Dog

Approx. Weight: 11 lb.  
P/N 20231

**7 5/8" BOLT CIRCLE KELLY BAR ADAPTERS**  
**For 15,000 ft. lb. maximum installing torque**

Each of these Kelly Bar Adapters has twelve holes for 5/8" bolts on a 7 5/8" bolt circle and comes with twelve 5/8" grade 2 bolts, nuts and lock washers, and bent arm pin with coil lock.



**2 1/2" Kelly Bar Adapter**

Shape: **Hex**  
 Weight: 23 lb.  
 Dimensions:  
 X: 2 1/2" Y: 4 3/8" Z: 8 1/4"  
 P/N 20140



**2 5/8" Kelly Bar Adapter**

Shape: **Hex**  
 Weight: 23 lb.  
 Dimensions:  
 X: 2 5/8" Y: 4 3/8" Z: 8 1/4"  
 P/N 20150



**3" Kelly Bar Adapter**

Shape: **Hex**  
 Weight: 27 lb.  
 Dimensions:  
 X: 3" Y: 3 1/2" Z: 8"  
 P/N 20411



**3" Kelly Bar Adapter**

Shape: **Square**  
 Weight: 23 lb.  
 Dimensions:  
 X: 3" Y: 3 1/2" & 2 1/16" Z: 7"  
 P/N 20451

**STANDARD LOCKING DOG ASSEMBLY**

For 15,000 ft. lb. maximum installing torque



**12 Bolt Locking Dog**

P/N 20170



**12 Bolt Locking Dog Replacement Kit**

P/N 20221

**ANCHOR INSTALLATION TOOLS**



**SAT-1**

P/N 20345



**SAT-80**

P/N 20340

## 7 FT. DRIVE-END WRENCH



### 7 ft. Drive-End Wrench

Red Bar  
Weight: 73 lb.  
P/N 20190



### 7 ft. Drive-End Wrench

Yellow Bar  
Weight: 64 lb.  
P/N 20250



### 7 ft. Drive-End Wrench

Orange Bar  
Weight: 57 lb.  
P/N 20060



### 7 ft. Drive-End Wrench

White Bar  
Weight: 73 lb.  
P/N 20321M

Part No.	Description	Weight, ea.
20190	Installs 15,000 ft.lb. (large hub) drive string system anchors 8,000 ft.lb. (large hub) drive string system and all 1½" core anchors	73 lb.
20250	Hybrid drive-end wrench installs 8,000 ft.lb. (large hub) anchors, 6,000 ft.lb. anchors, 7,000 ft.lb. anchors	64 lb.
20060	Standard drive-end wrench installs 8,000 ft.lb. (small hub) anchors, 10,000 ft.lb. (small hub) anchors, 4,000 ft.-lb. anchors, 6,000 ft.lb. anchors	57 lb.
20321M	Reduced drive-end wrench installs 8,000 ft.lb. (small hub) anchors, 10,000 ft.lb. (small hub) anchors, 4,000 ft.lb. anchors, 6,000 ft.lb. anchors (Fits 12 Bolt Locking Dog)	73 lb.



## 3 1/2 FT. DRIVE-END WRENCH



### 3 1/2 ft. Drive-End Wrench

Red Bar  
Weight: 36 lb.  
P/N 20180



### 3 1/2 ft. Drive-End Wrench

Yellow Bar  
Weight: 28 lb  
P/N 20240

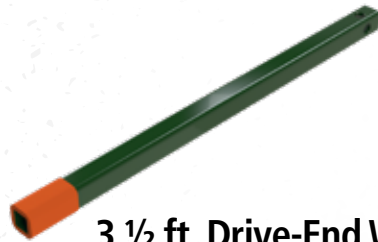

### 3 1/2 ft. Drive-End Wrench

Orange Bar  
Weight: 29 lb.  
P/N 20070

Part No.	Description	Weight, ea.
20180	Installs 15,000 ft.lb. (large hub) drive string system anchors 8,000 ft.lb. (large hub) drive string system and all 1 1/2" core anchors	36 lb.
20240	Hybrid drive-end wrench installs 8,000 ft.lb. (large hub) anchors, 6,000 ft.lb. anchors, 7,000 ft.lb. anchors	28 lb.
20070	Standard drive-end wrench installs 8,000 ft.lb. (small hub) anchors, 10,000 ft.lb. (small hub) anchors, 4,000 ft.lb. anchors, 6,000 ft.lb. anchors	29 lb.

## EXTENSION WRENCHES



### 3 1/2 ft. Extension Wrench

Red Bar  
Weight: 53 lb.  
P/N 20200



### 3 1/2 ft. Extension Wrench

Orange Bar  
Weight: 42 lb.  
P/N 20010



### 7 ft. Extension Wrench

Red Bar  
Weight: 89 lb.  
P/N 20210



### 7 ft. Extension Wrench

Orange Bar  
Weight: 70 lb.  
P/N 20020



## PERFORMANCE TEAM SET-UP (PTS)

It's quick and easy – that's why our customers love it.

No more hunting down the anchor installation parts, or swapping the Kelly bar because you no longer need one! Everything stays pinned up to the digger drive and runs off the locking dog.

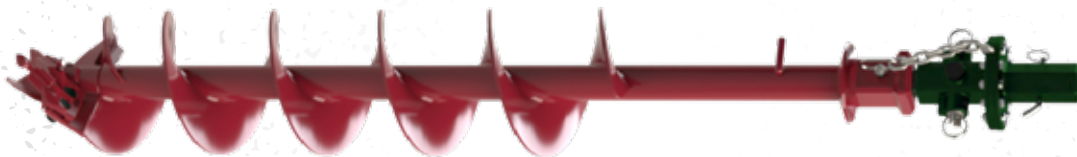



EXPLODED VIEW

#### **PERFORMANCE TEAM SET-UP AUGER:**

- Available in 16", 18", and 24" sizes (Other sizes available upon request)
- Dirt or carbide teeth
- Special PTS square drive box

#### **PERFORMANCE TEAM SET-UP:**

- 2 1/2" or 2 5/8" Kelly Bar adapter
- 12 Bolt Locking Dog
- Reduced end or red end anchor bar
- Bolt with click pin for Kelly Bar connection
- Chain with bolt and click pin
- Pin 5/8" x 6" with click pin, lanyard, swivel handle, for auger connection

# TRUCK ACCESSORIES

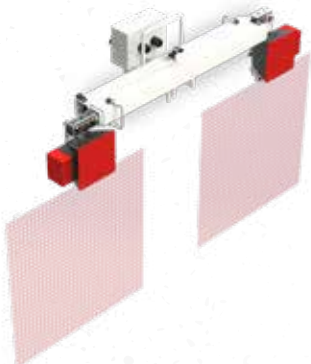

**Telescopic Light Bar Assembly**  
P/N 10000



**Threaded Pole Extractor**  
P/N 10020



**Swivel Sheave 16,000lbs**  
P/N 10045



**Swivel Sheave 30,000lbs**  
P/N 10050



**3/4" Diameter Cable Step**  
**Small Cable Step** (4-3/4" X 12")  
P/N 10055



**1 1/4" Diameter Cable Step**  
**Large Cable Step** (12" X 12")  
P/N 10060



CLOSED

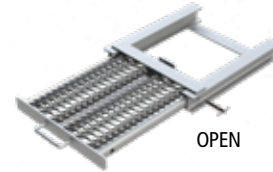

OPEN

**Pull Out Step** (14" X 24")  
P/N 10070



CLOSED



OPEN

**Ladder Step**  
P/N 10125



**Utility Pole Safety Light**  
P/N 10130



**Top Load Chock Block Holder**  
P/N 10165

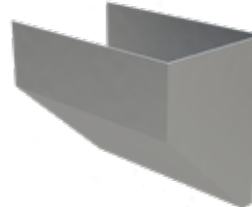

**Chock Block Holder**  
**Left Side**  
P/N 10170



**Chock Block Holder**  
**Right Side**  
P/N 10175



**Hook Rack Fixed** (3 Hooks)  
P/N 10180



**Hook Rack Swivel** (3 Hooks)  
P/N 10185



**Hook Rack Fixed** (6 Hooks)  
P/N 10210

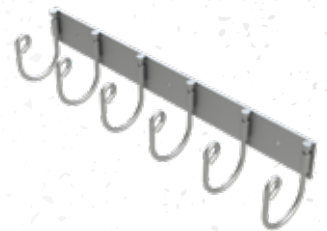

**Hook Rack Swivel** (6 Hooks)  
P/N 10215

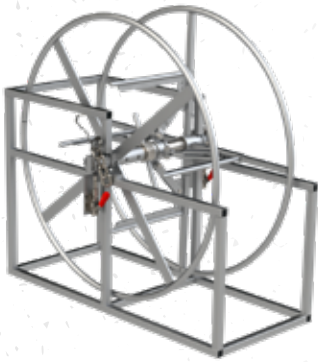

**Cage Spider Reel** (4-3/4" X 12")  
P/N 10255



**Guy Wire Spider Reel** (11" Wide)  
P/N 10260



**Guy Wire Basket** (6" Wide)  
P/N 10266

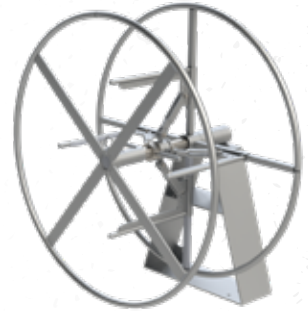

**"A" Frame Spider Reel**  
P/N 10280

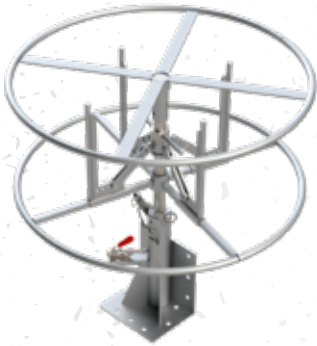

**Stand Up Spider Reel**  
P/N 10285



**Stand Up Spider Reel Base**  
P/N 10290



**Double Spider Reel**  
P/N 10295



**Duplex-Triplex Wire Basket**  
P/N 10300



**CB Draw Bar**  
P/N 10310



**Wire Storage Rack (Bicycle)**  
P/N 10330



**Outrigger Pad Rack Double**  
P/N 10395



**Trailer Jack Pivot Set**  
P/N 10510



**Bucket Rest Kit**  
P/N 10440



**4 Tube Scud Launcher**  
P/N 10475



**CR Reel**  
P/N 10305



# FLIGHTING

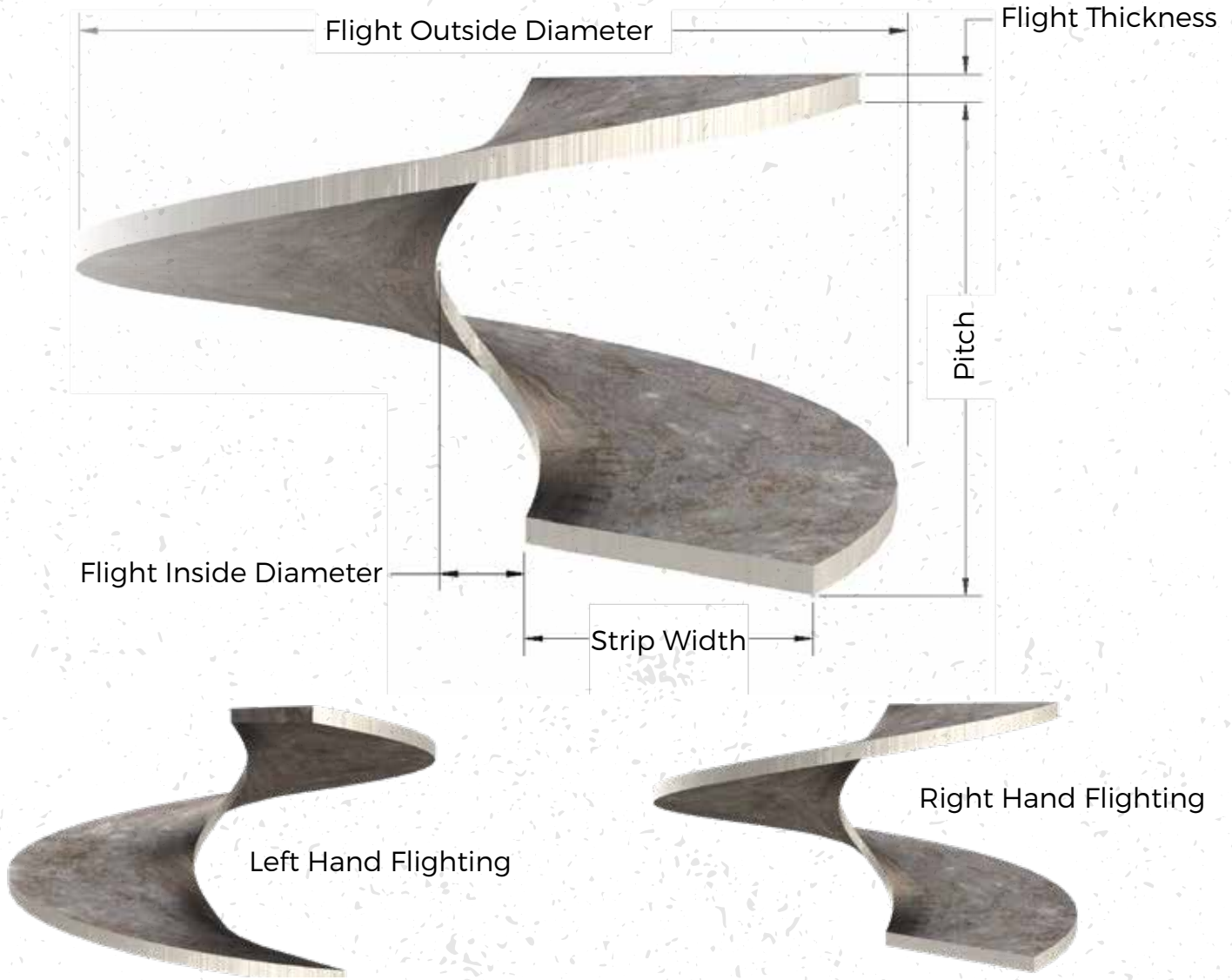

## SPECIFICATIONS NEEDED TO QUOTE:

- Outside diameter
- Pitch
- Inside diameter
- Thickness
- Specify right or left hand flighting





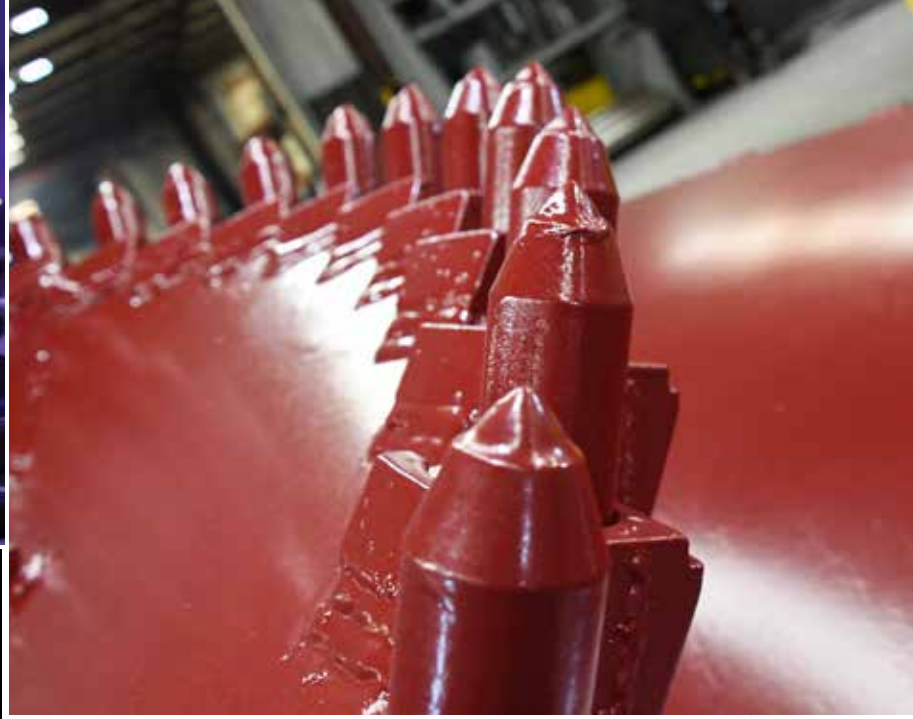

PROUDLY  
MADE IN THE USA

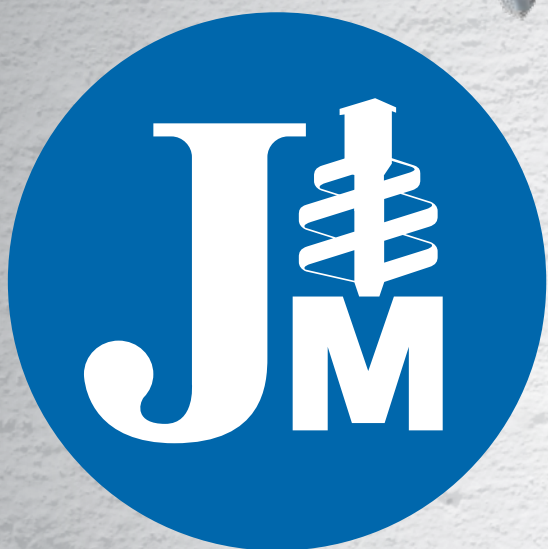

# JEFFREY MACHINE INC

DRIVEN BY PRECISION

**CORPORATE OFFICE**  
3841 Industrial Drive  
Birmingham, AL  
**205.841.8600**

**TEXAS**  
**817.545.8677**

**JeffreyMachine.com**

Specifications are subject to change without notice.

**BETEK**  
Teeth 

